

Qualcuno di cui ti puoi fidare
(Someone you can trust)

TYRE CHANGER

RASE.2124

Instruction Manual - EN

Version 2.0 - July 2016

I diritti di traduzione, di memorizzazione elettronica, di riproduzione e di adattamento totale o parziale con qualsiasi mezzo (compresi microfilm e copie fotostatiche) sono riservati. Le informazioni contenute in questo manuale sono soggette a variazioni senza preavviso.

Italiano

All rights of total or partial translation, electronic storage, reproduction and adaptation by any means (including microfilm and photocopies) are reserved. The information in this manual is subject to variation without notice.

English

Les droits de traduction, de mémorisation électronique, de reproduction et d'adaptation totale ou partielle par n'importe quel moyen (y compris microfilms et copies photostatiques) sont réservés.

Les informations contenues dans ce manuel sont sujettes à des variations sans préavis.

Français

Alle Rechte der Übersetzung, elektronischen Speicherung, Vervielfältigung und Teil- oder Gesamtanpassung unter Verwendung von Mitteln jedweder Art (einschließlich Mikrofilm und fotostatische Kopien) sind vorbehalten.

Die im vorliegenden Handbuch enthaltenen Informationen können jederzeit ohne Vorankündigung geändert werden.

Deutsch

Quedan reservados los derechos de traducción, de memorización electrónica, de reproducción y de adaptación total o parcial con cualquier medio (incluidos microfilmes y fotocopias). Las informaciones que se incluyen en este manual están sujetas a variaciones sin aviso previo.

Español

Elaborazione grafica e impaginazione

Ufficio **P**ubblicazioni **T**ecniche

**DICHIARAZIONE CE DI CONFORMITA'
CE DECLARATION OF CONFORMITY
DECLARATION DE CONFORMITE CE
CE - ÜBEREINSTIMMUNG
DEKLARACJA ZGODNOŚCI CE**

FASEP 2000 S.r.l. - Via Faentina, 96 - 50030 Ronta (FI) ITALY

dichiara sotto la propria esclusiva responsabilità che il prodotto:

declare on our own responsibility that the product:

Déclare sous son propre responsabilité que le produit:

erklärt unter ihrer eigenen Verantwortung, daß das Erzeugnis:

oświadcza na własną odpowiedzialność, że urządzenie:

Smontagomme ruote auto
Démonte-pneus roues voiture
Passengers car tyre-changer
PKW-Reifenmontiergerät
Montażownica do kół

Targhetta

al quale questa dichiarazione si riferisce E' CONFORME ALLE SEGUENTI DIRETTIVE:
to which declaration refers is IN CONFORMITY WITH THE FOLLOWING DIRECTIVES:

au quel cette déclaration se rapporte EST CONFORME AUX DIRECTIVES SUIVANTES:

darauf diese Erklärung Bezug nimmt, mit den folgenden Bestimmungen übereinstimmt:

do którego odnosi się niniejsza deklaracja, jest zgodne z następującymi dyrektywami:

2006/42/CE - 2011/65/UE

2014/29/UE

2014/35/UE - 2014/30/UE

ed alle Norme:

as well as to the following norms:

ainsi qu'aux normes suivantes:

und folgender Vorschrift gemäß:

oraz normami:

EN ISO 12100:2010

EN 60204-1:2006/AC:2010

EN 61000-6-2:2005/AC:2005

EN 61000-6-3:2007/A1:2011/AC:2012

Il firmatario della presente dichiarazione è la persona autorizzata a costituire il fascicolo tecnico

The signer of this declaration of conformity is the person authorized to provide for the technical file literature

Le signataire de cette déclaration de conformité est la personne autorisée à produire le dossier technique

Der Unterzeichner dieser CE-Übereinstimmung ist dazu ermächtigt, das technische Aktenbündel vorzulegen

Osoba wystawiająca niniejszą deklarację jest podmiotem upoważnionym do dostarczenia dokumentacji technicznej

Ronta.....



Fasep 2000 srl
Il legale Rappresentante
Boni Fulvio

Il modello della presente dichiarazione è conforme alla Norma EN ISO/IEC 17050-1
The model of present declaration is in conformity with directive EN ISO/IEC 17050-1
Le modèle de cette déclaration est conforme à la Norme EN ISO/IEC 17050-1
Das Modell dieser Erklärung übereinstimmt mit der Bestimmung EN ISO/IEC 17050-1
Egzemplarz niniejszej deklaracji jest zgodny z dyrektywą EN ISO/IEC 17050-1

ORIGINAL INSTRUCTIONS

CONTENTS

INTRODUCTION	6
TRANSPORT, STORAGE AND HANDLING	7
UNPACKING/ASSEMBLY	8
HOISTING/HANDLING.....	8
INSTALLATION	8
ELECTRICAL AND PNEUMATIC CONNECTIONS.....	9
SAFETY REGULATIONS	11
DESCRIPTION	12
MANUFACTURER'S LABEL	12
TECHNICAL DATA	13
STANDARD ACCESSORIES	14
ACCESSORIES SUPPLIED ON DEMAND.....	14
SPECIFIED CONDITIONS OF USE.....	14
MAIN OPERATING PARTS	15
WARNING SIGNALS.....	18
PRACTICAL HINTS.....	18
USE	19
DEMONTAGE.....	21
MONTAGE.....	22
INFLATION	23
MAINTENANCE	24
ENVIRONMENTAL INFORMATION	26
INFORMATION AND WARNINGS ABOUT OIL.....	28
RECOMMENDED FIRE-EXTINGUISHING DEVICES	28
GLOSSARY	29
TROUBLE SHOOTING	29
ELECTRICAL SYSTEM DIAGRAM.....	31
PNEUMATIC SYSTEM DIAGRAM	34

INTRODUCTION

The purpose of this manual is to furnish the owner and operator with a set of practical, safe instructions on the use and maintenance of the tyre changer.

Follow all the instructions carefully and the machine will give you the efficient and long-lasting service that has always characterized products, making your work considerably easier.

The following points define the levels of danger regarding the machine, associated with the warning captions found in this manual:

DANGER

Refers to immediate danger with the risk of serious injury or even death.

WARNING

Dangers or unsafe procedures that can cause serious injury or even death.

CAUTION

Dangers or unsafe procedures that can cause minor injuries or damage to property.

Read these instructions carefully before powering up the machine. Keep this manual and all illustrative material supplied with the machine in a folder near the tyre changer where it is readily accessible for consultation by the machine operators.

The technical documentation supplied is considered an integral part of the machine; and must always accompany the equipment if it is sold or transferred to a new owner.

The manual is only to be considered valid for the model with the serial number indicated on the nameplate applied to it.



WARNING

Observe the contents of this manual: the producer declines all liability in the case of uses of the machine not specifically described and authorized in this manual.



WARNING

This machine must be used only by qualified and authorized personnel. A qualified operator is construed as a person who has read and understood the tyre changer manufacturer's instructions as well as the tyres and wheel rims manufacturers', is suitably trained, and is conversant with safety and adjustment procedures to be adhered to during operations. Use of the machine by unskilled staff may constitute a serious risk for the operator and for the final user of the product processed (the wheel rim and tyre assembly).

NB:

Some of the illustrations in this manual have been taken from photographs of prototypes: standard production machines may vary in some respects.

These instructions are intended for people with basic mechanical skills. We have therefore omitted detailed descriptions of procedures such as how to loosen or tighten the fixing devices on the machine. Do not attempt to perform operations unless properly qualified and with suitable experience. In case of need, contact an authorized Service Centre for assistance.

TRANSPORT, STORAGE AND HANDLING

Conditions for transporting the machine

The tyre changer must be transported in its original packing and stowed in the position shown on the external packing.

- Packing dimensions:

- width 950 mm
- depth 1150 mm
- height 1080 mm

- Weight of the machine with packing:

- standard 286kg
- t.i. version 300kg

Ambient conditions for machine transport and storage

Temperature: $-25^{\circ} + 55^{\circ}\text{C}$.



WARNING

Do not stack other goods on top of the packing to avoid damaging it.

Handling

To move the packing, insert the tines of a fork-lift truck into the slots on the base of the packing itself (pallet) (fig. 1).

ATTENTION

Carry out the moving operations with great care, paying attention to move the packaged machine only from the side clearly indicated on the packaging.

Failure to follow these recommendations may result in damage to the machine and put the operator's safety at risk.

Before moving the machine, refer to the HOISTING/HANDLING section.

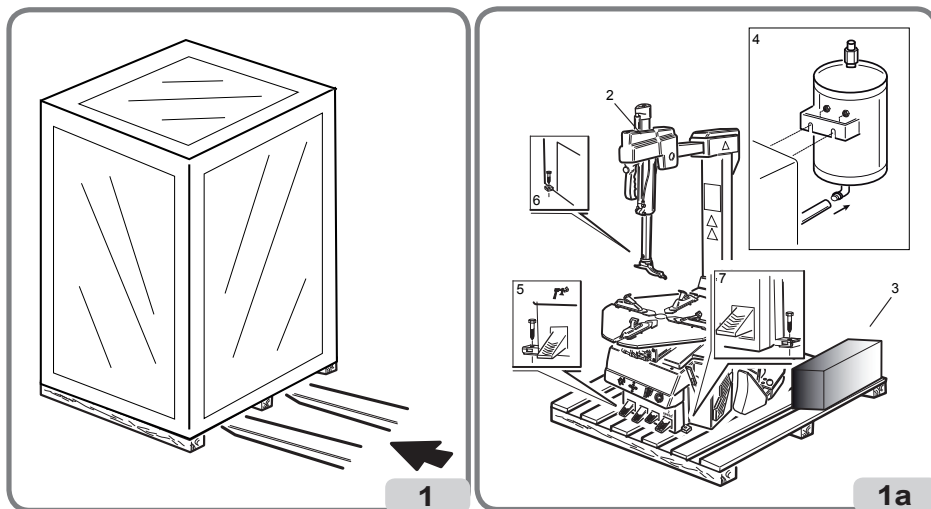

UNPACKING/ASSEMBLY



WARNING

Take utmost care when unpacking, assembling, hoisting and installing the machine as described in this heading.

Keep the original packing in good conditions to be used if the equipment has to be shipped in the future and make sure that the machine has not suffered damage in transit.

Failure to comply with these instructions may damage the machine and risk the operator's safety.

Remove the upper part of the packing.

The machine is fully assembled, comprising 3 main groups: 2- tyre changer, 3- accessories, 4 air tank (only for t.i. version).

Identify the points 5, 6 and 7 at which the machine is anchored to the pallet and proceed to remove fixing devices (fig. 1a).

Connect the tank union to the air connection pipeline provided, securing it with a band clamp.

Fix the air tank to the machine (fig. 1a). (T.I. version only).

HOISTING/HANDLING

To remove the machine from the pallet :

Lift the machine sideways enough to insert the forks of the fork-lift truck between the machine and the pallet as showed in fig.2.

At this point it is possible to release the working arm removing the cord which binds the arm to the turntable. This hoisting point must be used whenever you need to change the installation position of the machine. Do not attempt to move the machine until it has been disconnected from the electricity and compressed air supply systems.

INSTALLATION CLEARANCES



WARNING

The installation site must be chosen in strict compliance with the relevant regulations regarding Safety in the workplace.

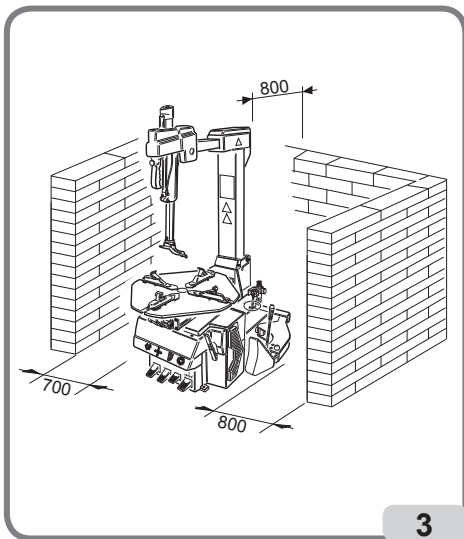
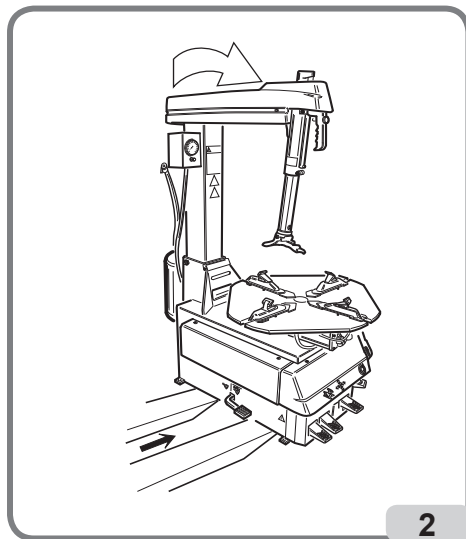

IMPORTANT: for correct, safe use of the equipment, users must ensure a lighting level of at least 300 lux in the place of use.



CAUTION

The installation of the machine must be performed in a dry area which must be protected from adverse weather conditions.

Install the tyre changer in the chosen work position, complying with the minimum clearances shown in fig. 3, adjust the height of the bead breaking support foot so that the machine is correctly positioned on the flooring.

Place the machine so that the plug-socket combination is easily accessible.

The machine must be placed on a horizontal surface, preferably concrete or tiled floor. Do not install on unstable or damaged surfaces.

The surface on which the machine rests must withstand the loads transmitted during operation. The surface must have a load-carrying capacity of at least 500 kg/m².

Ambient working conditions

- Relative humidity 50% (temp. 40°C) ÷ 90% (temp. 20°C) without condensation.

- Temperature 5°C ÷ 40°C.



WARNING

Use of the machine in a potentially explosive atmosphere is not permitted.

ELECTRICAL AND PNEUMATIC CONNECTIONS



WARNING

All operations required for the electrical connections of the equipment must be carried out exclusively by a qualified electrician.

Before connecting the air supply system, make sure the machine is set up as in fig. 4: pedal 3 and 4 totally downwards, column forward.

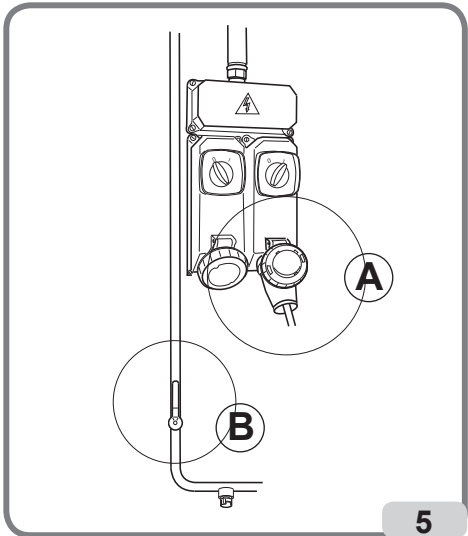
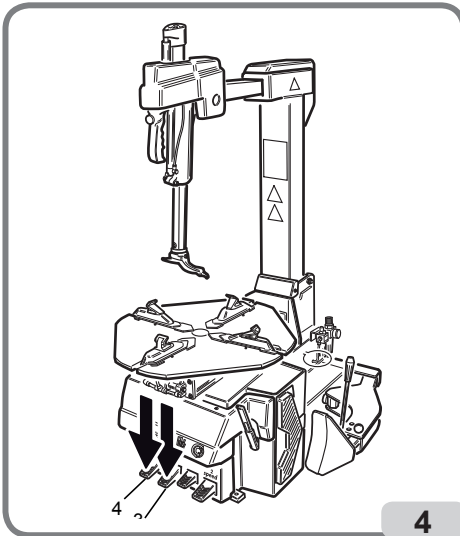

- The electrical supply must be suitably sized in relation to:
 - the machine input power as specified in the corresponding machine data plate;
 - the distance between the machine and the power supply hook-up point, so that voltage drops under full load do not exceed 4% (10% during start-up) compared with the rated voltage specified on the data plate.
- The operator must:
 - fit a power plug on the power supply lead in compliance with the relevant safety standards (A fig 5);
 - Connect the machine to an efficient grounding circuit in compliance with the relevant electric standards, provided with a circuit breaker (residual current set to 30mA);
 - fit fuses to protect the power supply line, rated as indicated on the general wiring diagram in this manual.
- In order to prevent the machine from being used by unauthorized personnel, it is advisable to disconnect the power supply plug when the machine remains idle (switched off) for long periods.



WARNING

A good grounding connection is essential for correct operation of the machine.

NEVER connect the earth wire to a gas or water pipe, telephone line or any other unsuitable objects.

Check that the pressure and flow-rate provided by the compressed air system are compatible with those required for proper operation of the machine - see "Technical Data" section. For correct machine operation the compressed air supply line must provide a pressure range from no less than 8 bar to no more than 16 bar.

Connect the compressed air system by means of a supply pipe connected to the intake of the air treatment unit on the REAR SIDE of the machine base.

Check that there is air lubrication oil in the Lubricating unit; refill if there is little or no oil. Use SAE20 oil. The customer must provide an air cut-off valve upstream of the air treatment and regulating device supplied with the machine.



WARNING

Connection 1 should be considered as an emergency valve to disconnect the machine from the air line (fig.6)

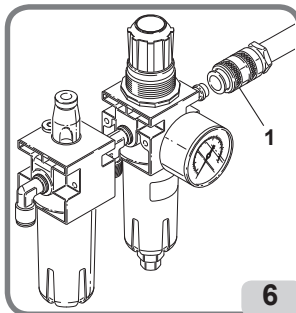

SAFETY REGULATIONS

The equipment is intended for professional use only.



WARNING

Only one operator may work on the equipment at a time.



WARNING

Failure to comply with the instructions and danger warnings may seriously injure operators and any other person present near the machine. Do not operate the machine until you have read and understood all the danger, warning and caution notices in this manual.

This machine must be used only by qualified and authorized personnel. A qualified operator is construed as a person who has read and understood the manufacturer's instructions, is suitably trained, and is conversant with safety and adjustment procedures to be adhered to during operations. Operators must not use the machine under the influence of alcohol or drugs which may affect their capacity.

The operator must, in all cases:

- Be able to read and understand all the information in this manual.
- Have a thorough knowledge of the capabilities of this machine.
- Keep unauthorized persons well clear of the area of operation.
- Make sure the machine has been installed in compliance with all relevant regulations and legislation.
- Make sure that all machine operators are suitably trained, that they are capable of using the equipment correctly and that they are adequately supervised.
- Never leave nuts, bolts, tools or any other equipment on the tyre changer as they may become entrapped between moving parts.
- Not touch power lines or the inside of electric motors or any other electrical equipment before making sure the power supply has been disconnected.
- Read this manual carefully and learn how to use the machine correctly and safely.
- Always keep this user and maintenance manual in an easily accessible place and consult it whenever necessary.



WARNING

Do not remove or deface the Danger, Warning or Instruction decals. Replace any missing or illegible decals. If one or more decals have been detached or damaged, replacements can be obtained from your nearest dealer.

- **When using and servicing the machine, observe the standardized industrial accident prevention regulations for high voltages.**
- Any unauthorized alterations or changes made to the machine shall automatically release the manufacturer from any liability for damage or accidents attributable to such modifications. Specifically, tampering with or removing the safety devices is a breach of the regulations for Safety in the workplace.
- User must wear personal protective equipment such as gloves, safety footwear and goggles.



WARNING

When operating or servicing the equipment, tie back long hair and do not wear loose-fitting clothes, ties, necklaces, rings or wristwatches which could become entrapped by moving parts.

DESCRIPTION

The machine is a electro-pneumatic tyre changer automatic, to be used with wheels with drop centre featuring weights and dimensions as described in the technical data section.

It is designed to work effectively on:

- Conventional wheels;
- Reverse rim wheels or wheels without central hole (use optional kit);
- Run-flat tyres with reinforced sidewalls*.

* **WARNING:** There are specifically studied procedures for this type of wheels.

NB: *It may be difficult and sometimes impossible to clamp and/or demount wheels of Vintage cars (cars out of production for over 30 years), some types of rally wheels and non-standardized street wheels.*

The machine is solidly constructed. It operates with the wheel in a vertical position for bead breaking and horizontal for mounting and demounting tyres. All machine movements are controlled by the operator by means of the pedals.

MANUFACTURER'S LABEL

Each machine carries a plate with its identification and some technical data.

As well as the manufacturer's details, it indicates:

Mod. - Machine model;

V - power supply voltage in Volts;

A - Input voltage in Amperes;

kW - Absorbed power in kW;

Hz - Frequency in Hz;

Ph - Number of phases;

bar - Operating pressure in bar;

Serial No. - Machine serial number;

EC - EC marking.

		<input type="text"/>				
		Mod.	<input type="text"/>			
		Ser. N.	<input type="text"/>			
		Volt	<input type="text"/>			
		Ph	<input type="text"/>			
	Year	<input type="text"/>	Kw	<input type="text"/>	Hz	<input type="text"/>
	Weight	<input type="text"/>	Amp.	<input type="text"/>	Bar	<input type="text"/>



WARNING

It is forbidden to modify or remove the data in the plate.

TECHNICAL DATA

- Overall dimensions (see fig. 7):
 - Length..... 1200/1500(t.i.) min 1730 max
 - Width 920 min 1250 max
 - Height 1650 min 1940 max
- Table top clamping capacity:
 - inside clamping 13"-25"
 - outside clamping 10"-22"
- Rim width:.....370 mm
- Maximum tyre diameter:.....1060 mm
- Bead breaking pressure:2900 Kg
- Air pressure8-10 Bar
- Motor electrical features:
 - 1ph version - 1 speed 220V - 50Hz 6A - 0,75 kW
 - 3ph version - 1 speed 230V - 50Hz 2,8A - 0,55 kW
 - 3ph version - 1 speed 400V - 50Hz 1,6A - 0,55 kW
 - 3ph version - 2 speed 230V - 50Hz 5,3/6,8A - 0,8/1,1 kW
 - 3ph version - 2 speed 400V - 50Hz 2,8/4,4A - 1,1/1,5 kW
- Weight.....255 kg (270 kg t.i.)
- Weight of electrical/ electronic components: 11,5 kg
- Noise level
 - A-weighted sound pressure level (LpA) at the working position..... < 70 dB (A)±3dB(A)

The noise levels indicated correspond to emission levels and do not necessarily represent safe operating levels. Although there is a relationship between emission levels and exposure levels, this can not be used reliably to establish whether or not further precautions are necessary. The factors which determine the level of exposure to which the operator is subject to include the duration of the exposure, the characteristics of the workplace, other sources of noise, etc. The permitted exposure levels may also vary according to the country. However, this information will enable machine users to make a more accurate assessment of hazard and risks.

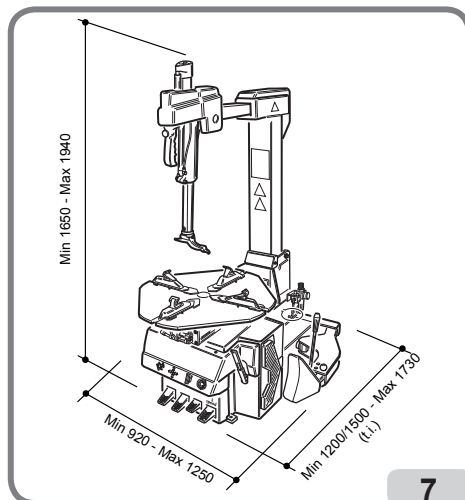

STANDARD ACCESSORIES

044900800..... Tyre lever
040000100..... Brush (BR)
3-01523 Grease 4Kg (TG4)

ACCESSORIES ON DEMAND

100012100..... UWA 24 (Adapters to increase the turntable clamping capacity)
100012000..... UMA Universal motorcycle adapters
100001500..... CRA Adapters for convex rims
8-11600005..... PLS 2 (Pneumatic wheel lift complete with roller rest)

SPECIFIED CONDITIONS OF USE

The TECO tyre changers has been designed exclusively for mounting and demounting tyres, using the tools the machines are equipped with, following the instructions in this manual.



WARNING

Any other operation carried out on the machine is considered as improper use and shall be construed as negligence.

These machines are equipped with an inflation system independent from any other function described above. Take great care when using it (read the INFLATION chapter).

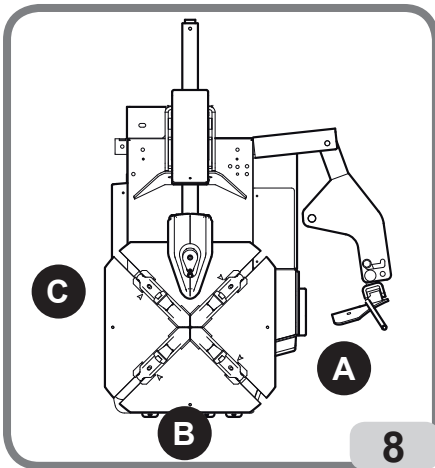

WARNING

You are strongly advised not to use equipment or tools not originally manufactured by TECO .

Figure 8 shows the positions assumed by the operator during the various stages of work with the machine.

A Bead breaker

B Tyre demounting and mounting

C Inflation area.



WARNING

Keep hands well away from machine moving parts.



WARNING

To stop the machine in an emergency:

- disconnect the power supply plug;
- isolate the compressed air supply network by disconnecting the (quick-coupling) shut-off valve (fig. 6).

MAIN OPERATING PARTS



WARNING

Get to know your machine: the best way to prevent accidents and obtain top performance is to get to know exactly how it works. Learn the function and location of all the controls. Check carefully that each of the controls operates properly. To avoid any risk of accidents and injuries, the machine must be installed and operated correctly and serviced regularly.

The machine main operating parts are shown in fig. 9:

- 1 Bead breaker pedal
- 2 Turntable rotation, 4 position-pedal:
 - released position = turntable still
 - pedal pressed down = rotation clockwise
 - pedal pressed deep down = rotation clockwise double-speed
 - pedal pulled up = rotation anti-clockwise
- 3 Clamp control pedal (to open and close the clamps)
- 4 Vertical post control pedal
- 5 Turntable
- 6 Clamp
- 7 Mounting/demounting tool
- 8 Working arm
- 9 Working arm cylinder (Pneumatic version)
- 10 Vertical post
- 11 Filter Regulator + Lubricator Unit (regulates pressure, filters, removes humidity of and lubricates the compressed air supplied)
- 12 Wheel support
- 13 Bead breaker blade
- 14 Tyre lever
- 15 Tubeless tyre inflation pedal (t.i. version)
- 16 Air tank(t.i. version)
- 17 Safety valve(t.i. version)
- 18 Deflation button(t.i. version)
- 19 Doyfe union to be fitted on the wheel's valve for inflation(t.i. version)
- 20 Pressure gauge(t.i. version)
- 21 Locking button:
 - A)** working arm ascent; **B)** working arm descent; **C)** locked
- 22 Inflating nozzles (t.i. version)

versione t.i.

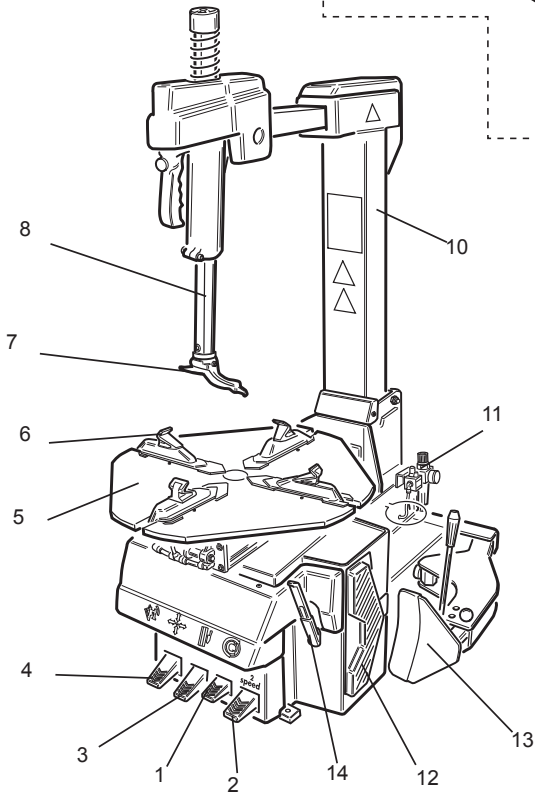
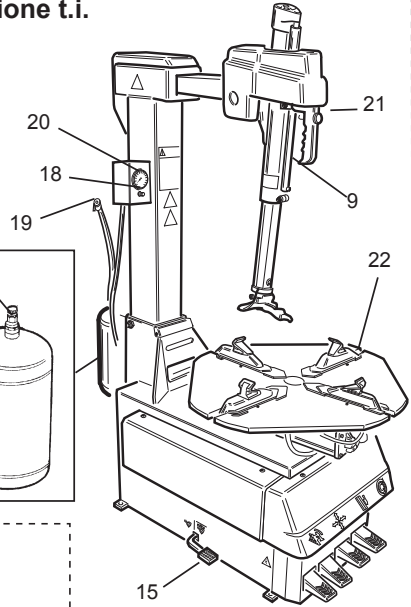
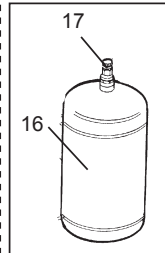
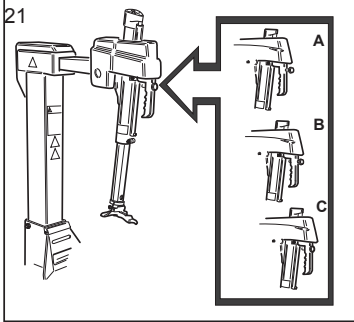

WARNING SIGNALS

PAY THE UTMOST ATTENTION TO THE WARNING LABELS ATTACHED TO THE MACHINE.
USING THE MACHINE WITHOUT READING THE WARNING SIGNALS MAY BE SERIOUSLY DANGEROUS FOR THE OPERATOR.

DANGER! INFLATING TIRES IS DANGEROUS
DANGER! LE GONFLAGE PEUT ETRE DANGEREUX
¡CUIDADO! EL INFLADO PUEDE SER PELIGROSO
GEFAHR! DAS FULLEN VON REIFEN KANN GEFAHRLICH SEIN
PERICOLO! IL GONFIAGGIO DEI PNEUMATICI E' PERICOLOSO



000103700



000103500

CAUTION: TOWER TILTING

EXPLOSION HAZARD!
DANGER D'EXPLOSION!
¡PELIGRO DE EXPLOSION!
EXPLOSIONSGEFAHR!
PERICOLO DI ESPLOSIONE!

GB Never exceed 3.5 Bar (50 PSI) while inflating. Always observe the instruction manual.

F No jamais dépasser 3,5 bars (50 PSI) pendant la mise en place du talon et le gonflage. Lire et observer la notice d'instructions.

E No superar jamás los 3.5 Bar (50 PSI) durante el acoplamiento del talón y el inflado. Leer y respetar las indicaciones del manual de instrucciones.

D Beim Reifentillen darf nie ein Druck über 3,5 bar (50 PSI) verwendet werden. Die Betriebsanleitung lesen und beachten.

I Non superare mai 3,5 Bar (50 PSI) durante la tallatura ed il gonfiaggio. Leggere e seguire il manuale istruzioni.



000103000



DANGER OF HAND CRUSHING BETWEEN CLAMP AND RIM.



000103100

DANGER OF HAND CRUSHING BETWEEN MOUNTING HEAD AND WHEEL.



CAUTION: AIR BLAST.



000102800

MAX. AIR SUPPLY LINE PRESSURE 16 BAR



000102700

INFLATING GUN CONNECTION.
DO NOT DIRECTLY CONNECT THE COMPRESSOR.
(only on standard version)

F

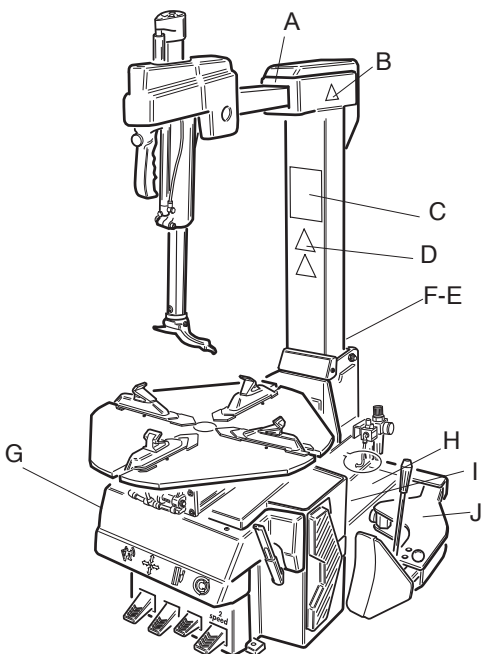

000103600

CAUTION: ELECTRIC CURRENT



000103400

DANGER OF CRUSHING PARTS OF THE BODY BETWEEN THE BEAD BREAKER AND THE MACHINE



000103200

DANGER OF CRUSHING PARTS OF THE BODY BETWEEN THE BEAD BREAKER AND THE WHEEL.



000103300

DANGER OF CRUSHING PARTS OF THE BODY BETWEEN THE BEAD BREAKER ARM AND THE MACHINE.

Preliminary checks

Check that there is a pressure of at least 8 bar on the pressure gauge of the Filter Regulator + Lubricator unit.

Check that the machine has been adequately connected to the power mains.

Deciding from which side of the wheel the tyre must be demounted

See fig. 10.

Find the position of the drop centre A on the wheel rim. Find the largest width B and the smallest width C. The tyre must be demounted or mounted with the wheel positioned on the turntable with the side with the smallest width C facing upward.

Special instructions

Some types of wheels on the market require special procedures and precautions which differ from the standard procedure.

This applies in particular to the following types of wheels:

Alloy rim wheels: some wheels have alloy rims where the drop centre A is very small or non-existent - fig. 10-B. These rims are not approved by the DOT (Department of Transportation) standards - these initials certify that tyres comply with the safety standards adopted by the United States and Canada (these wheels cannot be sold in these markets).



DANGER

Take utmost caution when mounting the tyre. The rim and/or the tyre may be damaged accidentally, with the risk of the tyre exploding during the inflation stage.

European style high-performance wheels (asymmetric curvature) - fig.10-C: some European wheels have rims with very pronounced curvature C, except in the area of the valve hole A where the curvature is less pronounced B.

On these wheels the bead must first be broken in correspondence with the valve hole, on both the top and bottom sides of the wheel.

Wheels with low pressure indicator system - fig.10-D.

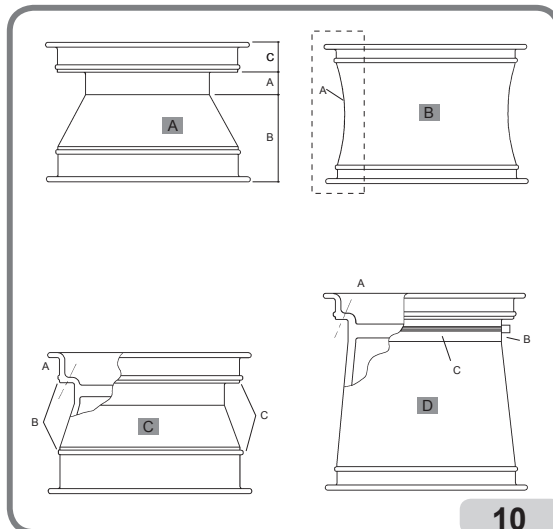

10

USE

BEAD BREAKING

The bead breaker arm of the machine is equipped with a patented system which allows to obtain two different working inclinations between the blade and the wheel.

- Fully close the turntable clamps (fig. 11) acting on pedal 3 fig. 9.
 - Remove the weights from the rim.
 - Fully deflate the tyre, removing the valve
 - Adjust the rim rest depending on wheel diameter
 - Adjust the inclination of the blade according to the wheel width by means of the pin in order to obtain a better inclination between the blade and the tyre: in position 1 in fig.12 for low width tyres, in position 2 for high width tyres
 - Place the wheel as shown in fig. 13 and take the blade near the bead, keeping the necessary safety distance between the rim and the bead breaker blade, so that the latter works on the tyre and not on the rim.
 - Press pedal 1 (fig 9) to activate the bead breaker and free the bead from the rim.
- Release the pedal. Pressing the bead breaker pedal (1 fig. 9) the arm moves (13 fig.9) and it may be dangerous (crushing danger); pay the utmost attention during bead breaking.

Repeat this operation on the other side of the wheel.

It may be necessary to break the bead at several points to free it completely.

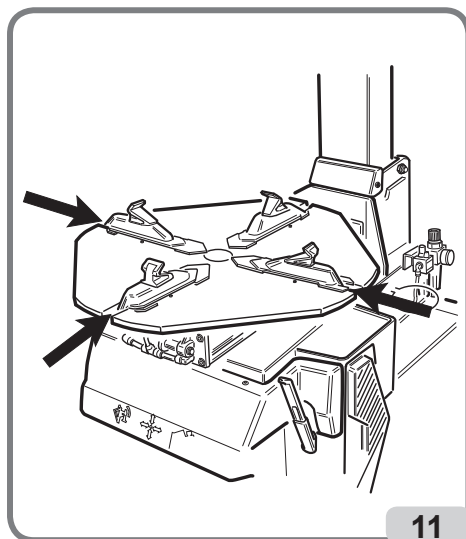

11

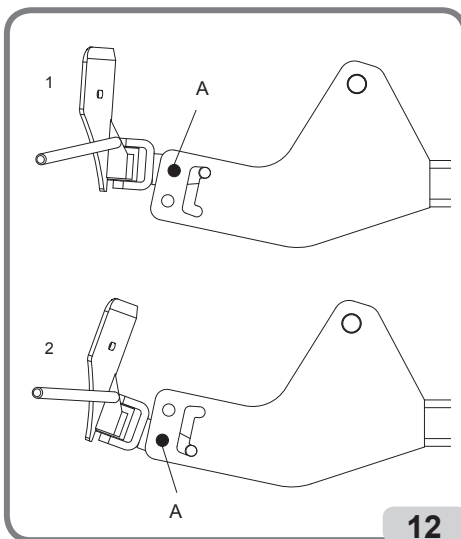

12

WHEEL CLAMPING

- Check if there are any weights left on the rim; if so, remove them.
- Thoroughly lubricate the sides of the tyre around the entire circumference of the lower and upper bead to facilitate the demounting and avoid damaging the beads (fig.15).
- Make sure that nobody is behind the tyre changer and tilt the tower backwards keeping the locking button in "locked" position.
- Depending on the diameter of the rim, close the four clamps if the rim is to be clamped from inside or open them if the rim is to be clamped from outside. Place the wheel on the turntable, push it lightly down and act on the control pedal to lock the wheel in its proper position (fig. 15).

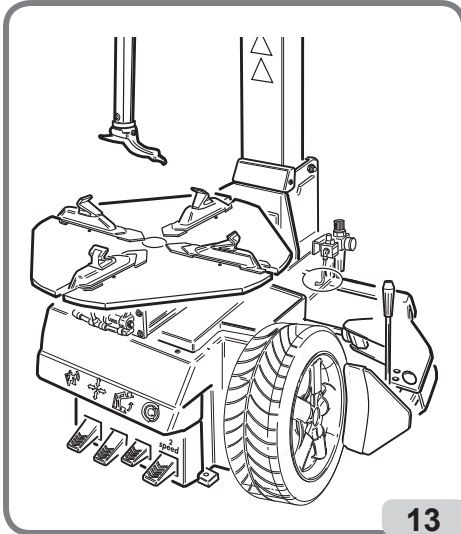

13

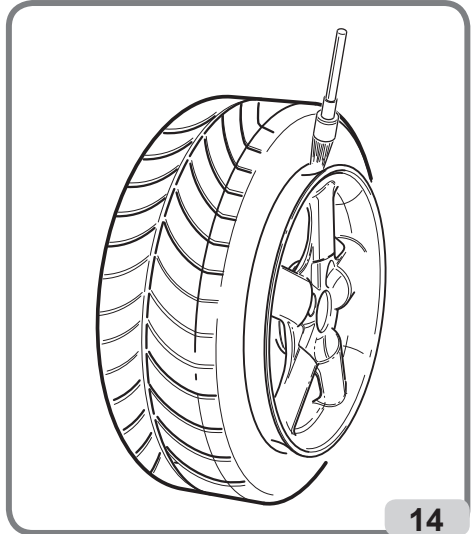

14

Acting on the turntable pedal (3 fig.9) closes the clamps and may be dangerous (danger of hand crushing). During rim clamping, do not keep the hands under the tyre.

• **Tool positioning (P version - fig.16)**

- Press the pedal 4 to move the column into its working position. Press the locking button into position A to contemporarily unlock working arm and horizontal arm. The tool will move upwards in its rest position.

With the locking button in position B, the tool can move freely downwards up to the rim edge or up to the minimum working height. Press the locking button in position C to contemporarily lock vertical and horizontal arms. In this case the tool will be automatically positioned at a security distance from the rim edge.

- Make the head go down on the rim (push button 18).

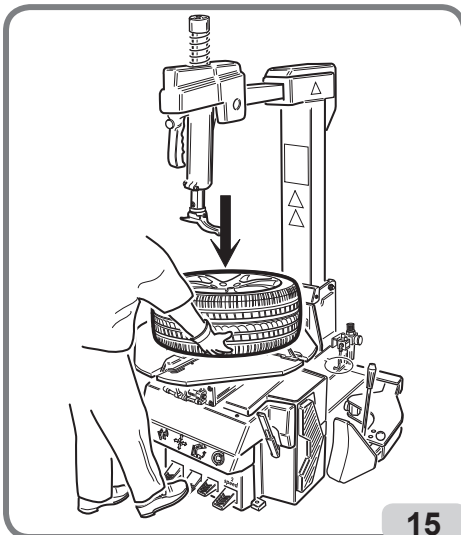

15

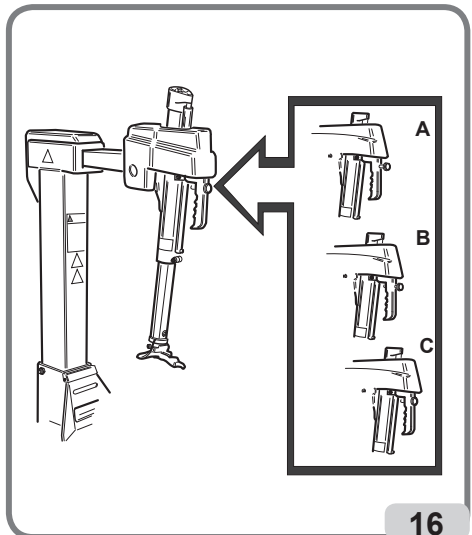

16

- For correct tool positioning, the insert (fig. 19) must be at the end position with the rim edge, where the vertical wall begins.

ATTENTION : Use the handle to achieve the correct tool positioning on the rim.

- Press the block 14 to fix the tool position.

The distance between rim and tool head will remain unchanged till the control button is in locking position. The operator can tilt the vertical post (i.e. when handling a set of tyres having same dimensions) without repositioning the tool on the rim.

ATTENTION : Risk of hand crushing between demounting / mounting tool and the wheel.

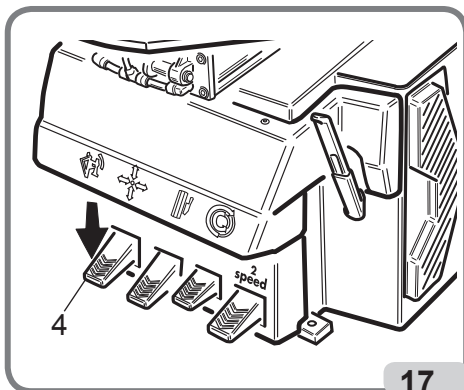

17

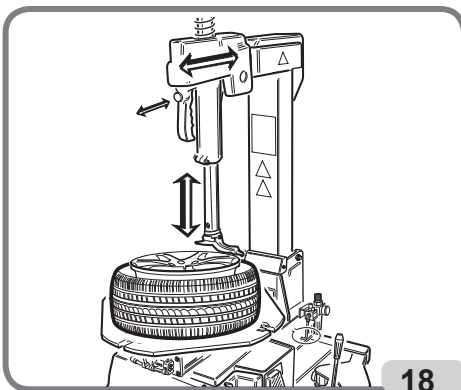

18

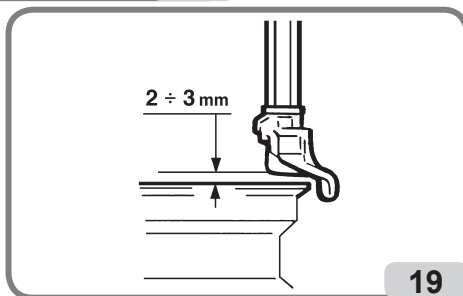

19

DEMOUNTING

• Upper bead demounting (fig.20)

- Move the working arm in work position, and lift the bead above the forward portion of the mounting head itself.
- Make sure that the tyre has not beaded in on the operator's side. If necessary, use a bead clamp and/or the bead pressing device.
- Make the turntable rotate clockwise by pressing the relevant pedal (2 fig.9) lightly and repeatedly, then keep the pedal continuously pressed.
- Rotate the wheel through one turn and at the same time press down with a hand on the side of the tyre opposite to the mounting head, in order to position the bead in the central groove of the rim.

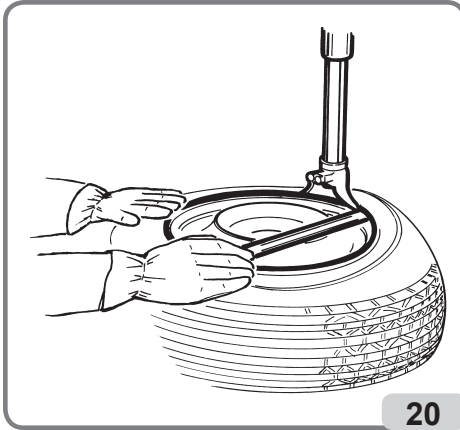

20

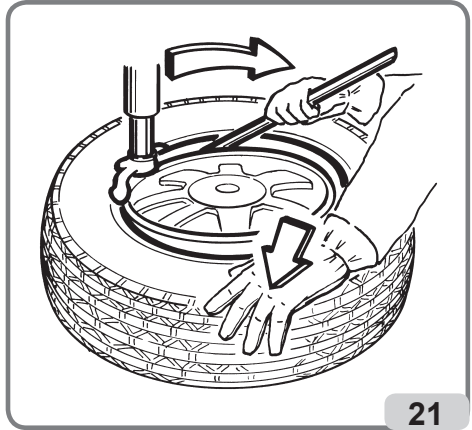

21

- **Lower bead demounting (fig. 21)**

- Lift the tyre nearby the tool.
- Use the tyre lever and hook the lower tyre bead.
- Acting on pedal 1, make the wheel turning till the complete demounting of the tyre from the rim

- **Demounting complete**

- At the end of the demounting activity, tilt the post using the on-purpose pedal (4 fig.9) and, then, remove the tyre.

MOUNTING



CAUTION

Always check that the tyre/rim combination is correct in terms of compatibility (tubeless tyre on tubeless rim; tube type tyre on tube type rim) and geometrical size (keying diameter, cross-section width, Off-Set and shoulder profile) before mounting.

Also check that rims are not deformed, that their fixing holes have not become oval, that they are not scaled or rusty and that they do not have sharp burrs on the valve holes.

Check that the tyre is in good condition with no signs of damage.

- **Tyre preparation (fig. 22)**

- Grease both the tyre beads.
- Place the tyre on the rim

- **Head positioning**

- Operate pedal (4) to move the head into its working position.

NB: The tool is already in the correct position for mounting the tyre, unless the type of rim has been changed.

- **Lower bead mounting**

- Place the bottom bead of the tyre underneath the tool and at the same time apply a little pressure to the tyre by hand while starting to rotate the wheel (pedal 1) for easier bead insertion.
- Rotate until tyre mounting is complete.

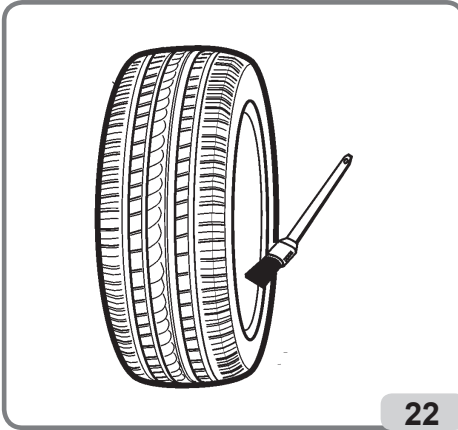

22

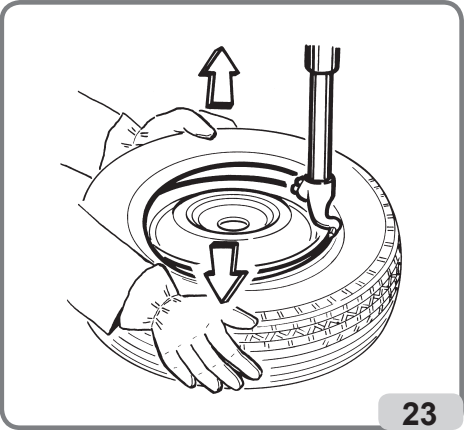

23

- **Upper bead positioning (fig. 23)**

- Position the upper tyre bead.

Take care that the tyre does not slip underneath the tool.

- **Upper bead mounting**

- Rotate the wheel using pedal 1 to start mounting the upper bead. Press manually the tyre bead to keep it inserted in the channel until the bead assembly is successfully completed.

- Return the tool into its rest position (control 4).

NOTE: for oversized (more than 19") or particularly tough wheels, it is recommended the use of the pneumatic bead presser. In this case the following procedure must be applied:

- **Tyre inflation**

- For inflation, see "INFLATION" section.

- **Tilt the tower backwards in non-work position by pressing the relevant pedal (pedal 4).**

- **Free the wheel from the clamps and remove it from the tyre changer.**

INFLATION



WARNING

Inflation is well known to be a dangerous operation. It must be carried out in accordance with the instructions below. Safety goggles with plain lenses and safety footwear must be worn.



CAUTION

During this operation, noise levels assessed at 85 dB(A) may occur. Operators are advised to wear hearing protection devices.



DANGER

Although the machine limits the pressure, it does not provide sufficient protection if the tyre bursts during inflation.

Failure to comply with the instructions below will render tyre inflation dangerous.

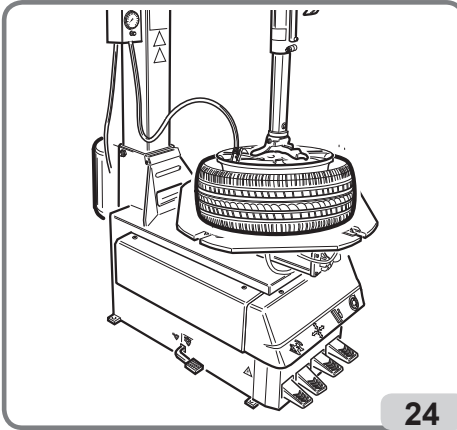

24

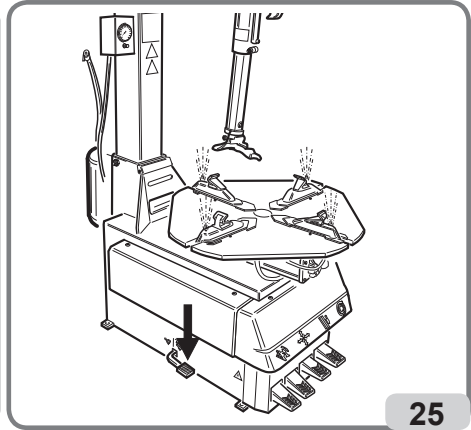

25



DANGER

NEVER exceed the pressure recommended by the tyre manufacturer. Tyres may burst if they are inflated beyond these limits or their structures may incur serious damage not visible at the time. KEEP YOUR HANDS AND THE WHOLE BODY WELL AWAY FROM THE TYRE DURING INFLATION. Make sure you are concentrated during this operation and check tyre pressure continuously to avoid excess inflation. A bursting tyre can cause serious injuries or even death.

- Release the wheel from the sliding clamps on the table top.
- Pull the horizontal arm all away out.
- Lower the vertical bar till it touches the rim.
- Lock the horizontal and vertical arms in the positions described on Fig.2.4.
- Connect the Doyfe inflation chuck (32) on the air hose to the valve stem.
- Inflate the tyre by using the inflation gun

Inflating tubeless tyres (T.I. versions only)

WARNING

Before carrying out the operations described below, always make sure that there is no dirt, dust or other impurities on the jaws near the air outlet holes.

- Make sure that the wheel is secured to the table top with inside clamping.
- Pull the horizontal arm all away out.
- Lower the vertical bar till it touches the rim.
- Lock the horizontal and vertical arms in the positions described on Fig.2.4.
- Connect the Doyfe inflator chuck on the air hose to the valve stem.
- Hold the tyre with your hands and lift it until there is a slight gap between the lower bead and bottom edge of the rim in order to close the upper bead and the top of the rim.
- Press the inflation pedal fully down for a short period to the bead seating position (fig.25). The tyre will expand and the beads will seat.
- Continue to press the pedal in the inflation position (fig.25) until the beads are completely sealed.

Note: to improve the operation of the tubeless tyre inflation system the compressed air line pressure must be between 8/10 bar.

Mounting head quick change device

Teco patented system integrated inside the hexagonal vertical arm which allows changing mounting heads in seconds without reducing the original machine working capacity (370 mm). To change the head, loosen the mounting head hexagonal locking screw using the standard supplied short wrench, pull the head down, mount the other head and tighten the hexagonal screw using the standard supplied wrench.

For a correct functioning of the device, take care there are no plays between head and hexagonal bar.

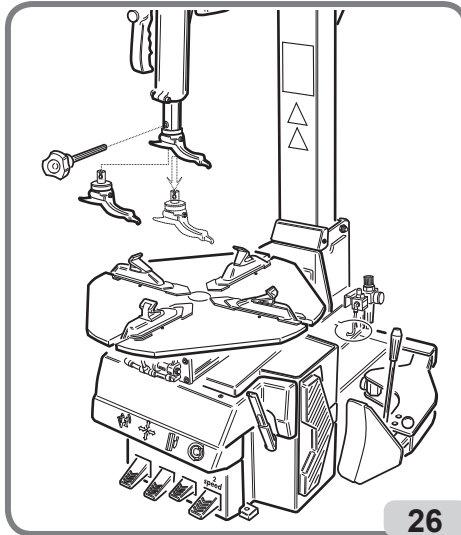

MAINTENANCE



CAUTION

The “Spare parts” handbook does not authorize users to carry out work on the machine with the exception of those operations expressly described in the user manual. It only enables users to provide the technical assistance service with precise information in order to minimize delays.



WARNING

TECO declines all liability for claims deriving from the use of non-original spare parts or accessories.



CAUTION

Any operation intended to modify the setting value of the relief valves or pressure limiter is forbidden. The manufacturer declines all liability for damage resulting from tampering with these valves.



WARNING

Before proceeding with any adjustment or maintenance activity, disconnect the machine from the air supply and electrically insulate the machine by means of an omnipolar disconnection device. Make sure that all the mobile parts are locked.

**CAUTION**

In case of replacement of the power supply cable, follow the indications listed in the table below for the most appropriate cable choice:

SUPPLY	CABLE TYPE	NR OF WIRES	WIRE SECTION
400/3/50 400/3/60 230/3/50 230/3/60 200/3/50 200/3/60	FROR 450-750V UNEL 35011	3 - phase 1 - grounding	1mm ²
240/1/50 230/1/50 220/1/60	FROR 450-750V UNEL 35011	1 - phase 1 - neutral 1 - grounding	1,5mm ²
115/1/60	UL 1569 300V 105°C	1 - phase 1 - neutral 1 - grounding	AWG 14

**CAUTION**

Do not remove or modify any parts of this equipment except in the case of service operations.

**DANGER**

When the machine is disconnected from the air supply system, the devices marked with the warning sign shown above may remain pressurised.

- The filter+regulator+lubricator is equipped with a semiautomatic condensation drain device. This device operates automatically whenever the compressed air supply to the machine is cut off. Drain the condensation manually (push-button d, fig 27) when the level exceeds the mark X, fig. 27.
- Check daily the correct tightening of the hexagonal screw (Fig. 26).
- Clean the top plate of the turntable every week: remove any accumulated dirt and clean with environmentally-friendly solvents.
- Monthly checks:
 - Clean the arms of the tool-carrying head, the bead breaking unit and the relative travel screws with environmentally-friendly solvents only. Lubricate.
 - Check the oil level in the air lubricator (fig. 27) and, if necessary, top up with non-detergent SAE20 oil to the indicated level Z.
 - Clean with a dry cloth. Avoid contact with solvents.
 - Check the oil flow-rate through the transparent cover K (correct flow-rate: 1 drop of oil every 4 bead breaking cycles). Adjust if necessary by turning the set screw Y fig. 27.

**CAUTION**

Keep the working area clean.
Never use compressed air, jets of water or solvent to remove dirt or deposits off the machine.
When cleaning, take care not to create and raise dust as far as possible.

ENVIRONMENTAL INFORMATION

The following disposal procedure shall be exclusively applied to the machines having the crossed-out

bin symbol  on their data plate.

This product may contain substances that can be hazardous to the environment or to human health if it is not disposed of properly.

We therefore provide you with the following information to prevent releases of these substances and to improve the use of natural resources.

Electrical and electronic equipment should never be disposed of in the usual municipal waste but must be separately collected for their proper treatment.

The crossed-out bin symbol, placed on the product and in this page, remind you of the need to properly dispose of the product at the end of its life.

In this way it is possible to prevent that a not specific treatment of the substances contained in these products, or their improper use, or improper use of their parts may be hazardous to the environment or to human health. Furthermore this helps to recover, recycle and reuse many of the materials used in these products.

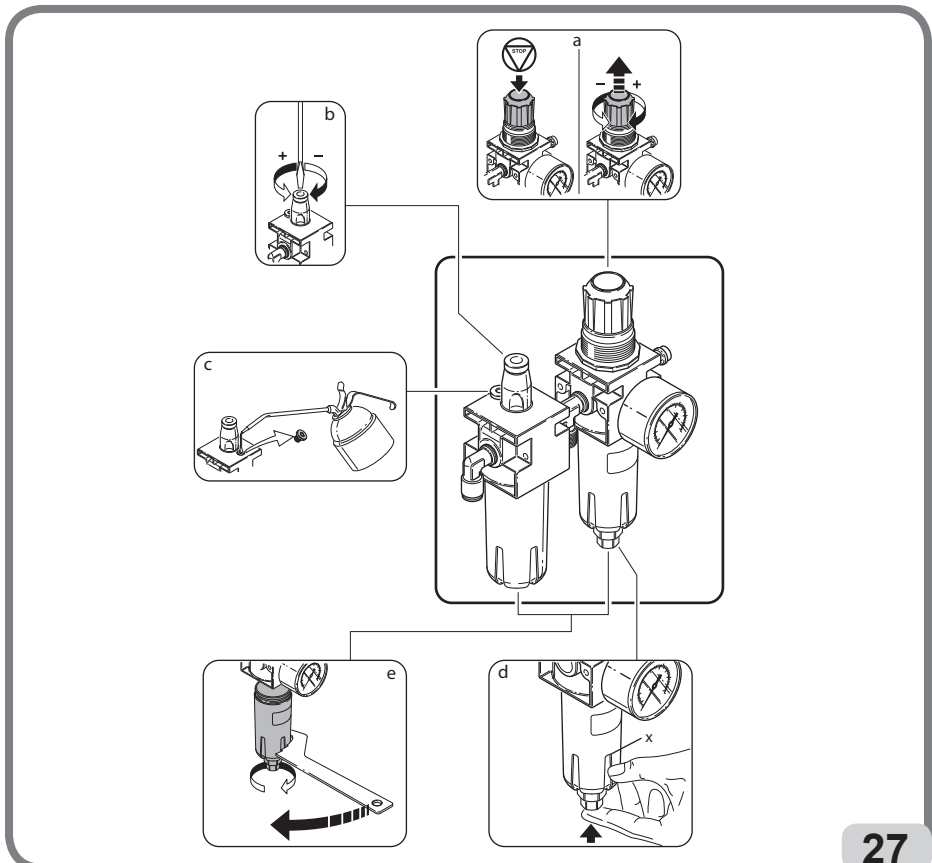

For this purpose the electrical and electronic equipment manufacturers and dealers set up proper collection and treatment systems for these products.

At the end of life of your product contact your dealer to have information on the collection arrangements. When buying this new product your dealer will also inform you of the possibility to return free of charge another end of life equipment as long as it is of equivalent type and has fulfilled the same functions as the supplied equipment.

A disposal of the product different from what described above will be liable to the penalties prescribed by the national provisions in the country where the product is disposed of.

We also recommend you to adopt further measures for environment protection: recycle the internal and external packing of the product and properly dispose of dead batteries (if contained in the product).

With your help the amount of natural resources used to produce electrical and electronic equipment can be reduced, the use of landfills for the disposal of the products, minimized, and the quality of life improved by preventing that potentially hazardous substances are released into the environment.

INFORMATION AND WARNINGS ABOUT OIL

Disposing of old oil

Do not dispose of used oil in sewers, storm drains, rivers or streams; collect it and consign it to an authorized disposal company.

Oil spills or leaks

Contain the spilt product from spreading using soil, sand or any other absorbent material. Degrease the contaminated area with solvents, taking care to disperse solvent fumes. The residual cleaning material must be disposed of as prescribed by law.

Precautions for the use of oil

- Avoid contact with the skin.
- Do not allow oil mists to form or spread in the atmosphere.
- Observe the following elementary health precautions:
 - protect against oil splashes (appropriate clothing, protective guards on machines);
 - wash frequently with soap and water; do not use cleaners or solvents that can irritate your skin or remove its natural protective oil;
 - do not dry hands with dirty or greasy rags;
 - change clothing if impregnated with oil, and in any case at the end of every working shift;
 - do not smoke or eat with greasy hands.
- Also adopt the following preventive and protective equipment:
 - gloves resistant to mineral oils, with lining;
 - goggles, in case of splashes;
 - aprons resistant to mineral oils;
 - screens to protect against oil splashes.

Mineral oil: first aid procedures

- Swallowing: seek medical attention, providing the characteristics of the type of oil swallowed.
- Inhalation: in case of exposure to high concentrations of fumes or mists, take the affected person to the open air and seek medical attention immediately.
- Eyes: rinse with plenty of running water and seek medical attention as soon as possible.
- Skin: wash with soap and water.

RECOMMENDED FIRE-EXTINGUISHING DEVICES

For guidance on the most suitable type of extinguisher, refer to the table below:

	Dry materials	Flammable liquids	Electrical equipment
Water	YES	NO	NO
Foam	YES	YES	NO
Powder	YES*	YES	YES
CO ₂	YES*	YES	YES

YES* Use only if more appropriate extinguishers are not at hand or when the fire is small.



WARNING

This table contains general instructions intended to be used as guidelines for users. Contact the manufacturer for details of the applications of each type of extinguisher.

GLOSSARY

Air delivery regulator: Union allowing regulation of the air flow.

Beading: Operation which takes place during inflation and ensures perfect centring between the bead and the rim edge.

Bead breaking: Operation in which the bead of the tyre is detached from the edge of the rim.

Bead pressing gripper: A tool intended for use when mounting the top bead. It is fitted so that it grips the shoulder of the rim and holds the tyre top bead inside the drop centre. It is generally used for mounting low profile tyres.

Tubeless Inflator: An inflation system which simplifies inflating tubeless tyres.

Bead: The edge of the tyre that remains in contact with the rim when the tyre is installed.

Tubeless: A tyre without an inner tube..

TROUBLE SHOOTING



CAUTION

In case of unexpected failure, electrically insulate the machine by means of an omnipolar disconnection device.

Turntable not turning

Feeding plug not connected or defective.

- Check the plug.

Machine not powered.

- Restore the electric connections.

Defective inverter.

- Replace the inverter (skilled staff needed in this case).

Motor shorted.

- Replace the motor (skilled staff needed in this case).

Belt broken.

- Replace belt.

Rotation control pedal fails to return to central position

Control spring broken.

• Replace the control spring.

Bead breaker pedal and table top pedal do not return to home position

Control spring broken.

- Renew the spring.

No oil in lubricator.

- Top up lubricator with SAE20 non-detergent oil.

Air leak inside the machine

Air leak from bead breaker cock.

- Renew the cock.
- Renew bead breaker cylinder.

Air leak from the table top cock.

- Renew table top cylinder.
- Renew swivel connector.

Bead breaker cylinder lacks force, fails to break beads and leaks air

Silencer plugged.

- Renew silencer.

Cylinder seals worn.

- Renew seals.
- Renew bead breaker cylinder.

Bead breaker cylinder leaks air around the rod

Air gaskets worn.

- Replace gaskets.
- Replace bead breaker cylinder.

Table top will not rotate in either direction

Inverter faulty.

- Replace inverter.

Belt broken.

- Renew belt.

Gear unit broken.

- Renew gear unit.

Gear unit noisy. The table top makes 1/3 of a spin and then stops

Gear unit seizing.

- Replace gear unit.

Table top fails to clamp wheels

Table top does not clamp rim.

- Renew table top cylinder.

Table top mounts or demounts wheels with difficulty

Insufficient belt tension.

- Adjust tension or replace belt.

Vertical slide ascends under strain

Defective clamping plate.

- *Renew plate.*

Clamping plate not adjusted.

- Adjust plate.

Vertical and horizontal limit stops do not operate

No air passing through clamping handle / valve.

- Check hose circuit.
- Replace handle / valve.

Column does not tilt

Column tilting cylinder faulty.

- Replace column opening cylinder.

No air supply to cylinder.

- Hoses folded.
- Replace valve.
- Check tightness of arm pivot.

Clamping arm cylinders leak air

Faulty piston or gaskets.

- Replace pistons and gaskets.

Column tilts violently or too slowly

Incorrect release valve setting.

- Adjust air delivery regulators on control valve.

Tyre pressure gauge needle fails to return to 0

Pressure gauge faulty or damaged.

- Replace pressure gauge.



WARNING

The “Spare parts” handbook does not authorize users to carry out work on the machine with the exception of those operations expressly described in the user manual. It only enables users to provide the technical assistance service with precise information in order to minimize delays.

WIRING DIAGRAM fig 28

AP1	Single / two-speed motor circuit board
M1	Motor
SQ1	Two-speed micro-switch
SQ2	Micro-switch (CLOCKWISE rotation)
SQ3	Micro-switch (ANTICLOCKWISE rotation)
XB1	Connector
Z1	Mains filter

Versione con Motoinverter

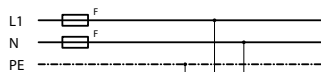

Power	F: Fuse	
	Phase	Neutral
200-230V / 1 / 50-60 Hz	250V, 12A	250V, 12A

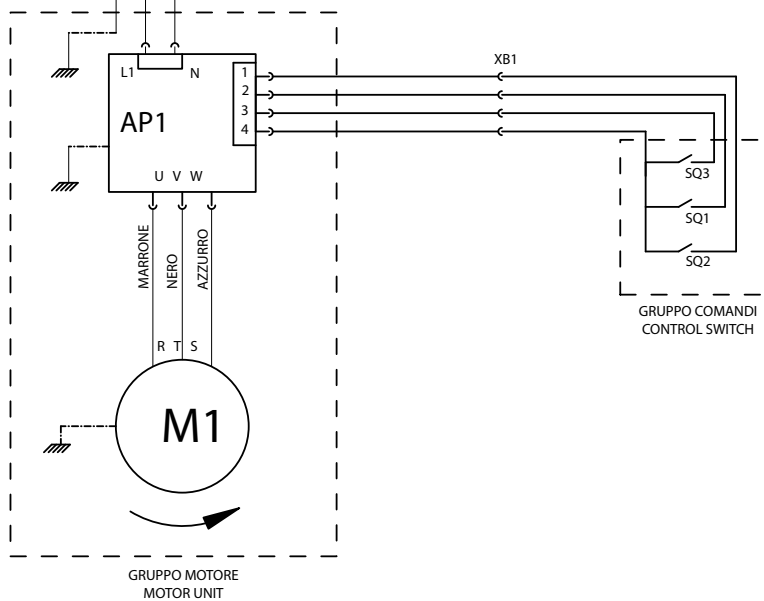

Power	F: Fuse Phase
400V / 3 / 50 Hz	500V, 6A
230V / 3 / 50 Hz	250V, 16A
400V / 3 / 60 Hz	500V, 6A
230V / 3 / 60 Hz	250V, 12A

X																					6	23-24	
	X																				x	21-22	
X																						5	19-20
	X																					4	17-18
		X																			X	4	15-16
		X	X																		X	4	13-14
X																						3	11-12
	X																					3	9-10
																					X	2	7-8
X	X																					2	5-6
X	X	X																				1	3-4
																					X	1	1-2
L2	L1	0	R																				

CONTATTI - Contacts

ELEMENTI - Elements

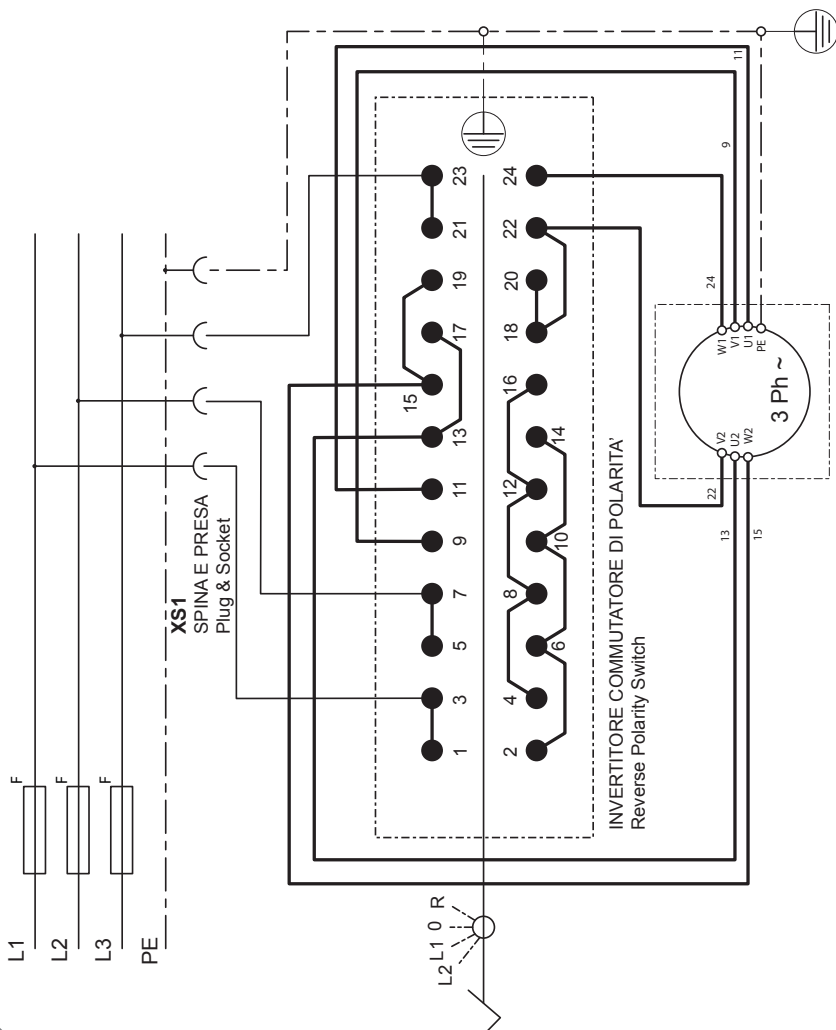

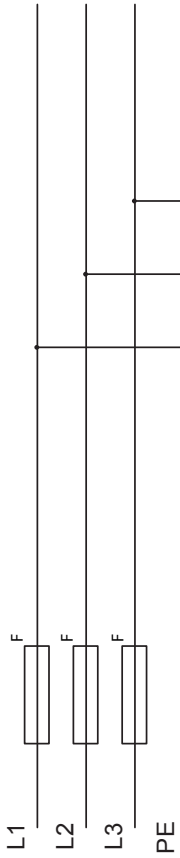

XS1
SPINA E PRESA
Plug & Socket

INVERTITORE COMMUTATORE DI POLARITA'
Reverse Polarity Switch

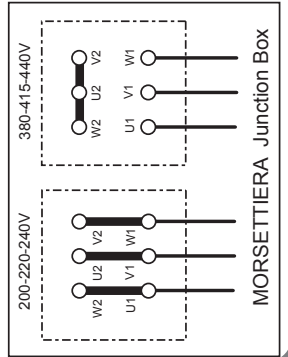
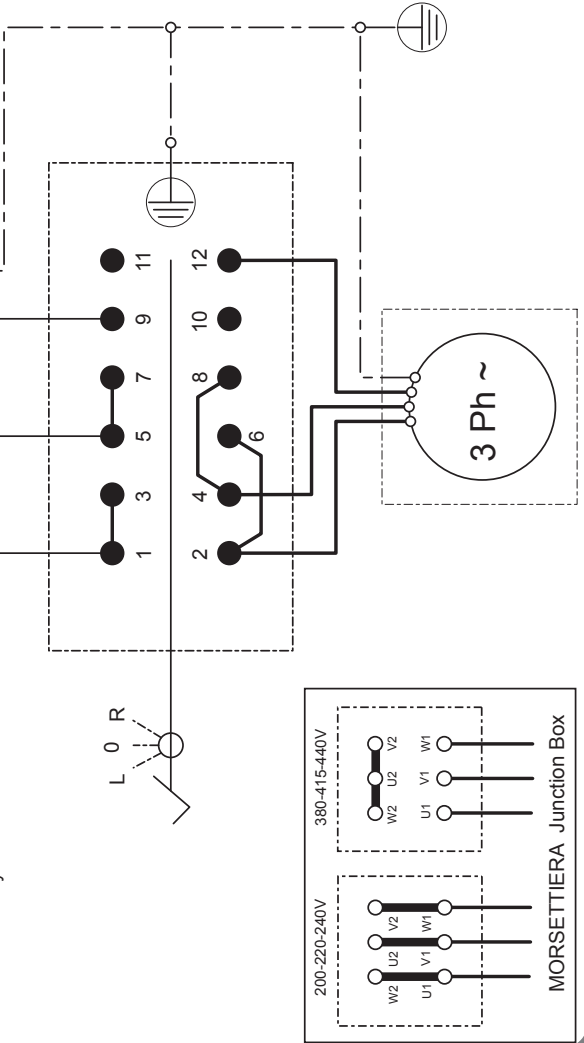

MORSETTIERA Junction Box

Power	F: Fuse Phase
400V / 3 / 50 Hz - 0,55 kW	500V, 4A
400V / 3 / 50 Hz - 0,75 kW	500V, 6A
230V / 3 / 50 Hz - 0,55 kW	250V, 10A
230V / 3 / 50 Hz - 0,75 kW	250V, 10A
200V / 3 / 50 Hz - 0,75 kW (Japan)	250V, 10A

X					11-12
	X				9-10
X					7-8
			X		5-6
			X		3-4
X				1	1-2
L	0	R			

— CONTATTI - Contact

— ELEMENTI - Element

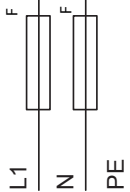

XS1
SPINA E PRESA
Plug & Socket

INVERTITORE COMMUTATORE DI POLARITA'
Reverse Polarity Switch

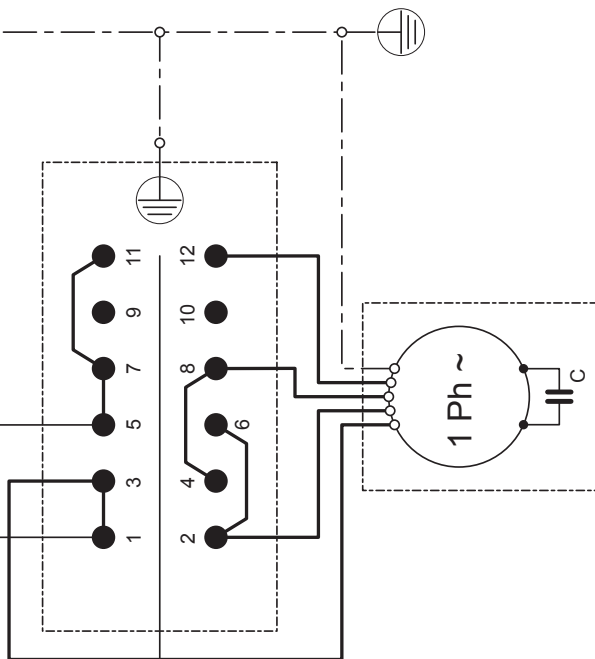
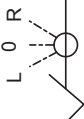

Power	F: Fuse	
	Phase	Neutral
230V / 1 / 50 Hz	250V, 16A	250V, 16A
240V / 1 / 50 Hz	250V, 16A	250V, 16A
220V / 1 / 60 Hz	250V, 16A	250V, 16A
115V / 1 / 60 Hz	250V, 20A	250V, 20A

x							11-12
		x					9-10
x							7-8
				x			5-6
				x			3-4
x						1	1-2
L	0	R					

CONTATTI - Contacts

ELEMENTI - Elements

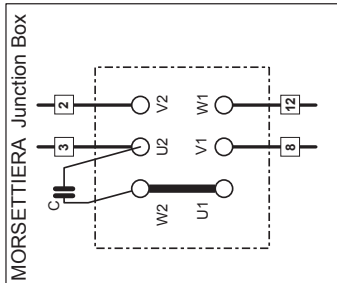

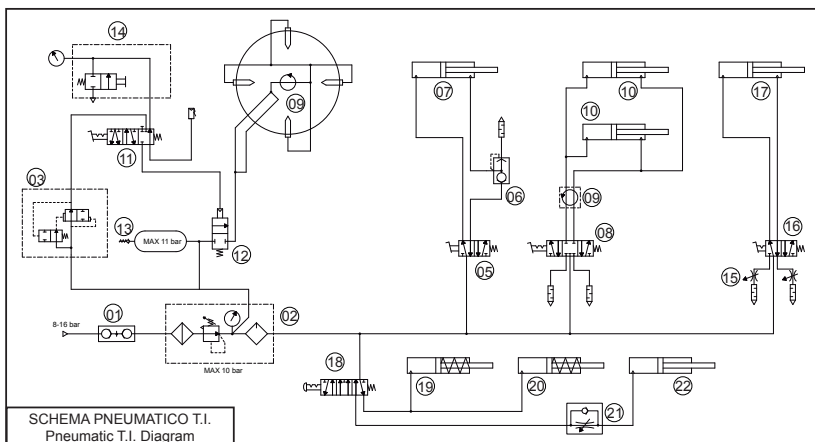
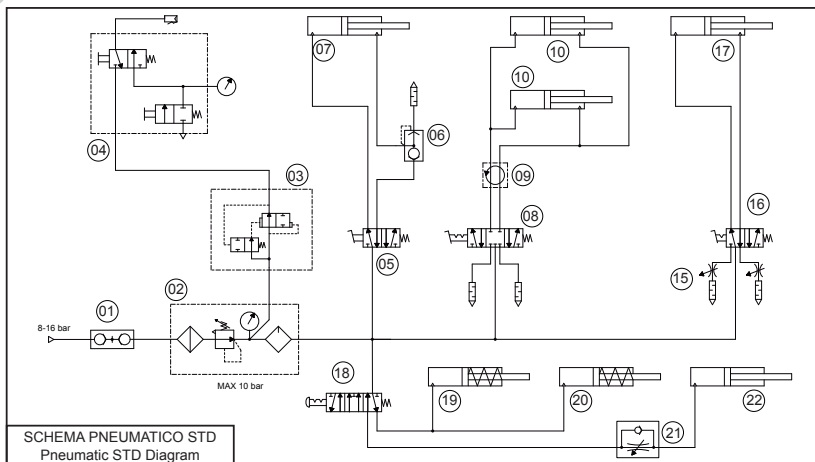

REF.	DESCRIZIONE	DESCRIPTION
01	INNESTO RAPIDO MASCHIO	QUICK UNION
02	GRUPPO FRL	WATER SEPARATOR AND PRESSURE REGUL+LUBRIFICATOR
03	VALVOLA GONFIAGGIO RAPIDO	QUICK INFLATING VALVE
04	PISTOLETTA DI GONFIAGGIO	INFLATING GUN AND GAUGE
05	VALVOLA STALLONATORE	BEAD BREAKING VALVE
06	VALVOLA SCARICO RAPIDO	QUICK DISCHARGED VALVE
07	CILINDRO STALLONATORE	BEAD BREAKING CYLINDER
08	VALVOLA AUTOCENTRANTE	SELF-CENTERING CHUCK VALVE
09	RACCORDO GIREVOLE	ROTATING UNION
10	CILINDRO AUTOCENTRANTE	SELF-CENTERING CHUCK CYLINDER
11	VALVOLA DI GONFIAGGIO	INFLATING VALVE
12	VALVOLA A MEMBRANA	VALVE
13	VALVOLA DI SICUREZZA	SAFETY VALVE
14	UNITA' DI GONFIAGGIO	INFLATE UNION BOX
15	SILENZIATORI REGOLABILI	REGULATE SYLENCER
16	VALVOLA PALO VERTICALE	VERTICAL POST VALVE
17	CILINDRO PALO VERTICALE	VERTICAL POST CYLINDER
18	PULSANTE BLOCCAGGIO BRACCIO	LOCKING HORIZONTAL ARM BUTTON
19	CILINDRO BLOCCAGGIO BRACCIO	LOCKING HORIZONTAL ARM CYLINDER
20	CILINDRO BLOCCAGGIO ASTA VERT	LOCKING VERTICAL SHAFT CYLINDER
21	VALVOLA DI REGOLAZIONE	REGULATION VALVE
22	CILINDRO SOLLEVAMETNO ASTA	VERTICAL SHAFT LIFTING CYLINDER

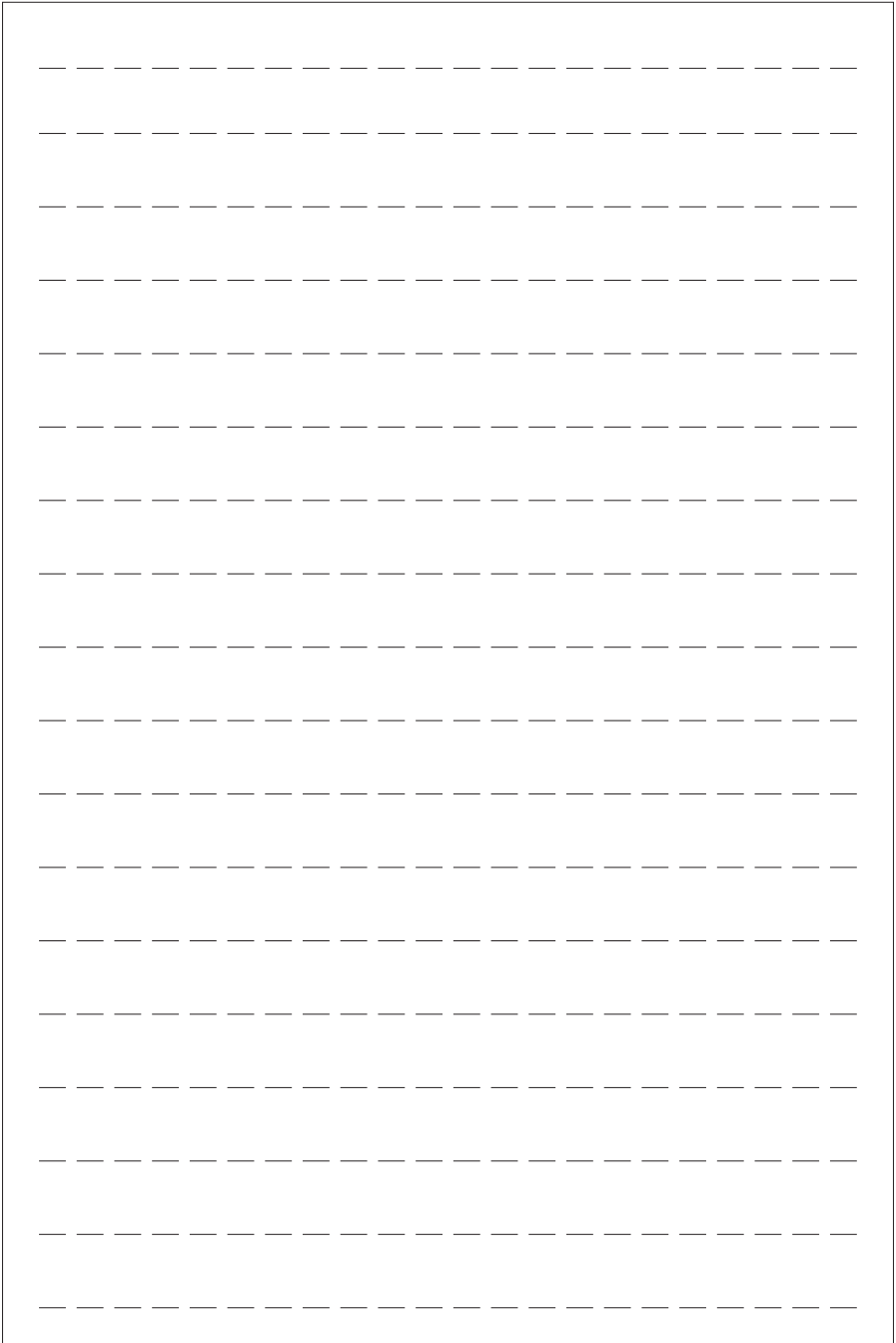

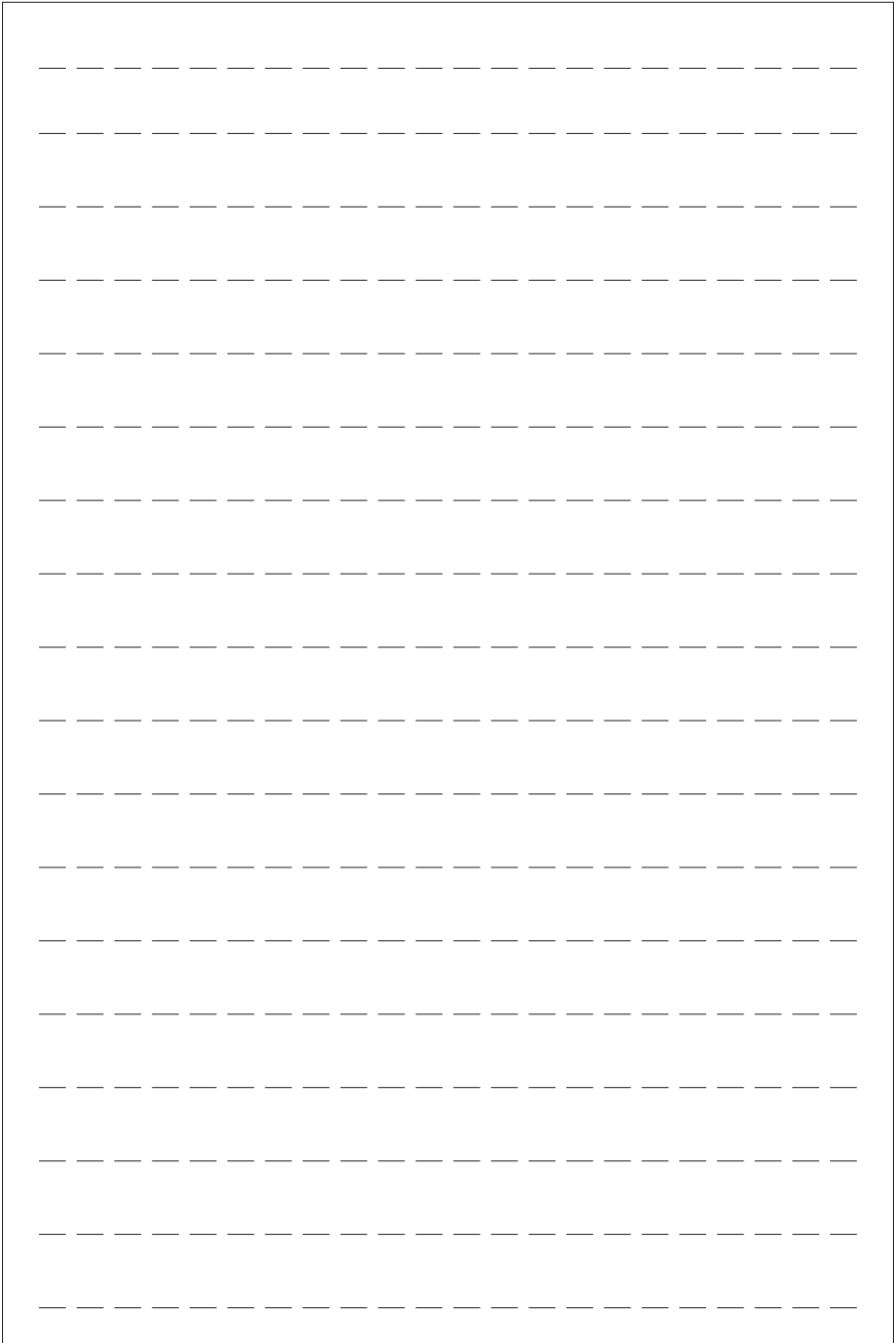

FASEP™ 
MADE IN ITALY