



Operating Instructions



ATH-Pure Lift

Pure Lift 2.40



ATH-Heinl GmbH & Co. KG | Gewerbepark 9
D-92278 Illschwang | Germany | www.ath-heinl.de
Stand: April 2022. Fehler und Irrtümer vorbehalten. Verkauf nur über ATH-Vertriebspartner.





Content

1.0	INTRODUCTION	- 3 -
1.1	General Information.....	- 3 -
1.2	Description.....	- 4 -
1.3	Operation.....	- 5 -
1.4	Technical Data	- 6 -
1.5	Scale Drawing	- 8 -
2.0	INSTALLATION	- 9 -
2.1	Transport & Storage Conditions	- 9 -
2.2	Unpacking the machine.....	- 9 -
2.3	Delivery Contents	- 10 -
2.4	Location.....	- 11 -
2.5	Fixing	- 13 -
2.6	Electrical Connection.....	- 14 -
2.7	Pneumatic Connection.....	- 14 -
2.8	Hydraulic Connection	- 15 -
2.9	Assembly	- 15 -
2.10	Theses.....	- 20 -
3.0	OPERATION	- 21 -
3.1	Operating Instructions	- 21 -
3.2	Basic Information	- 22 -
4.0	MAINTENANCE	- 25 -
4.1	Consumables for installation, maintenance and servicing.....	- 25 -
4.2	Safety Regulations for Oil	- 26 -
4.3	Notes	- 26 -
4.4	Maintenance or Service Plan	- 27 -
4.5	Troubleshooting / Error Display and Solutions	- 31 -
4.6	Maintenance and Service Instructions.....	- 33 -
4.7	Disposal.....	- 34 -
5.0	EG-/EU-KONFORMITÄTSERKLÄRUNG / EC-/EU-DECLARATION OF CONFORMITY.....	- 35 -
6.0	APPENDIX	- 36 -
6.1	Pneumatic circuit diagram	- 36 -
6.2	Electric circuit diagram.....	- 37 -
6.3	Hydraulic circuit diagram	- 38 -
7.0	WARRANTY CARD.....	- 39 -
7.1	Scope of the Product Warranty	- 40 -
8.0	INSPECTION LOG	- 41 -
8.1	Installation and Handover Log	- 42 -
8.2	Inspection Plan.....	- 43 -
8.3	Visual inspection (authorised expert).....	- 44 -
9.0	NOTES.....	- 50 -

1.0 INTRODUCTION

1.1 General Information

	<p>THESE INSTRUCTIONS ARE AN INTEGRAL PART OF THE MACHINE. THEY MUST BE READ AND UNDERSTOOD BY THE USER. NO LIABILITY IS ASSUMED FOR ANY DAMAGES CAUSED BY FAILURE TO FOLLOW THESE INSTRUCTIONS OR THE VALID SECURITY PROVISIONS.</p>
---	--

	<p>WARNING: Follow the instructions to prevent injury or damage.</p>
---	--

	<p>TIP: Provides more information on functionality and tips for using the device efficiently.</p>
---	---

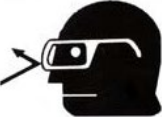
	<p>Appropriate protective clothing must be worn for all work on the described system.</p>
--	---

1.2 Description

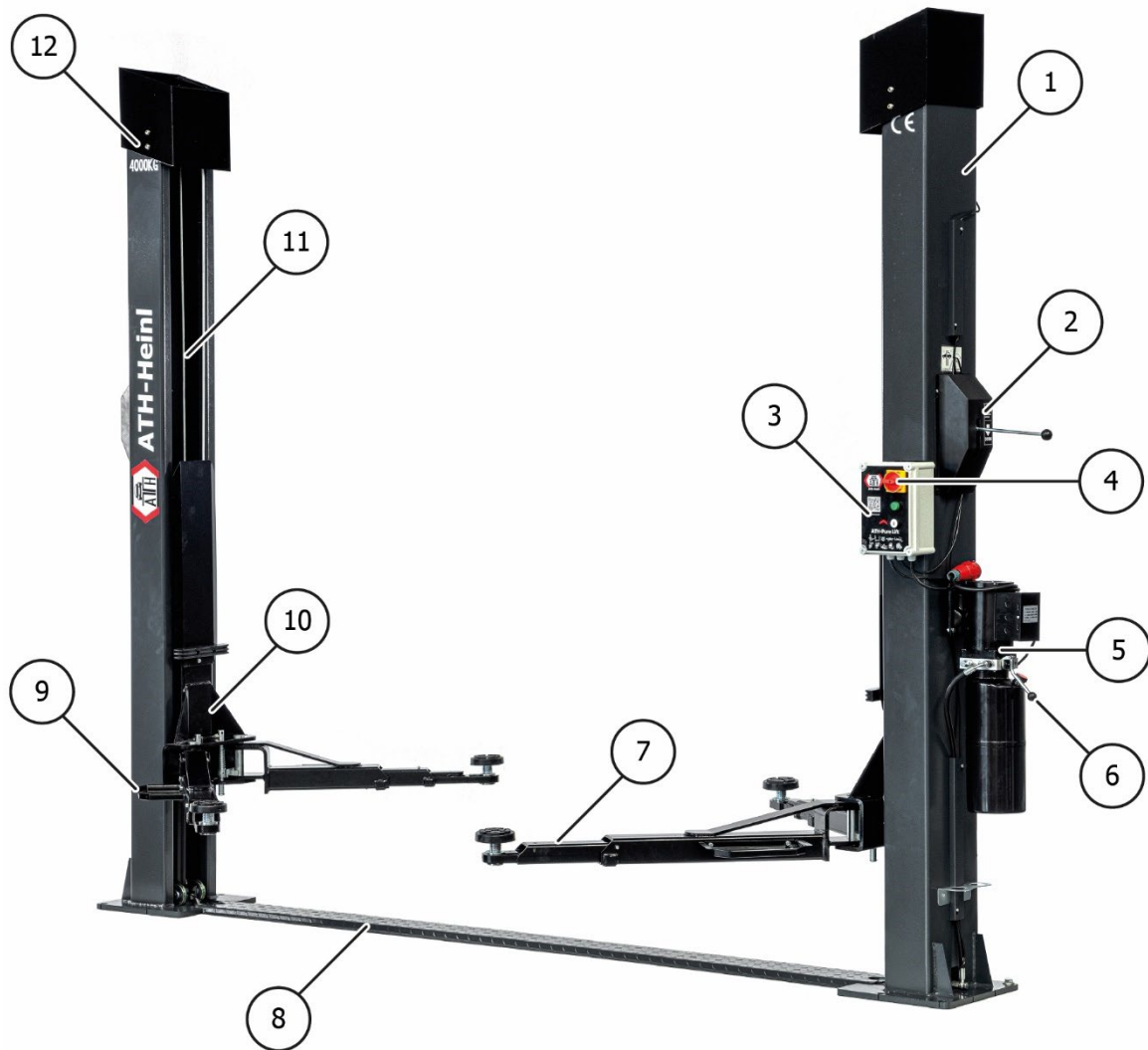

①	Lifting columns	⑦	Support arms
②	Manual release for safety catch	⑧	Drive-over plate to protect ropes and hoses
③	Control box	⑨	Foot protection (deflector bar)
④	Main switch	⑩	Pallet truck
⑤	Hydraulic power pack	⑪	Synchronizing ropes
⑥	Manual lowering valve	⑫	Cover of the columns

1.3 Operation

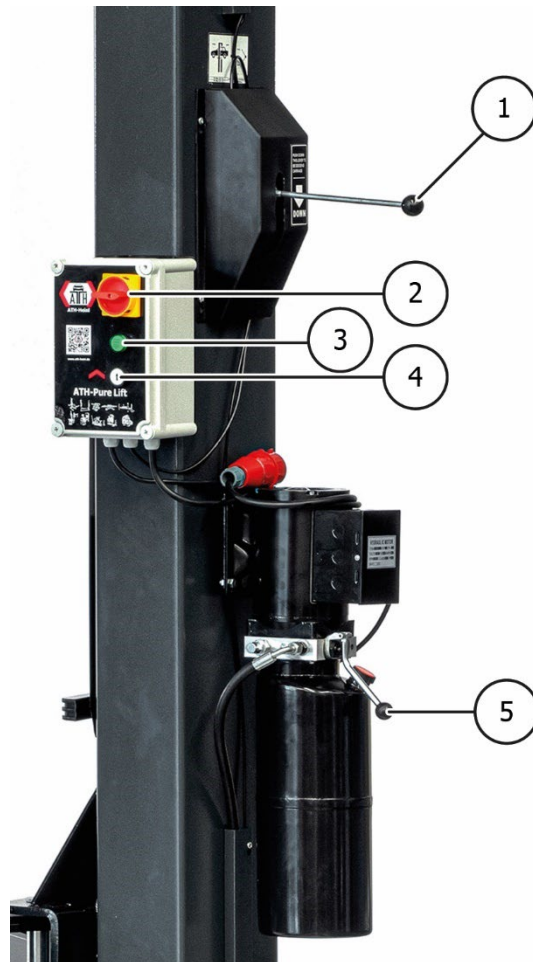

①	Manual release for safety catch	④	Lift button
②	Main switch	⑤	Manual lowering valve
③	Operation light		

1.4 Technical Data

Type	Pure Lift 2.40 230V	Pure Lift 2.40 400V
Max. Load capacity	4000Kg	
Lifting time (at 2,000 kg)	Ca.35 s	
Lowering time (at 2,000 kg)	Ca.35 s	
Electrical system	1/230V/50Hz	3/400V/50Hz
Control voltage	DC24V	
engine	2,2 KW	
Electrical protection	1 C 16 A	3 C 16 A
Power cord	Min. 3 x 1,5mm ²	Min. 5 x 1,5mm ²
Protection class	IP 43	
Hydraulic pressure	125 -145 bar	
Hydraliköl viscosity	Summer: H-LPD 32 (e.g.: OEST H-LPD 32 DD L) Winter: H-LPD 22	
Amount of oil	ca. 11l	
Attachment proposal	Chemical anchor: M16 x 250 (e.g.: Fischer FIS A M 16 x 250)	
Lot	12 x	
Noise	≤ 80 dB	

Load distribution

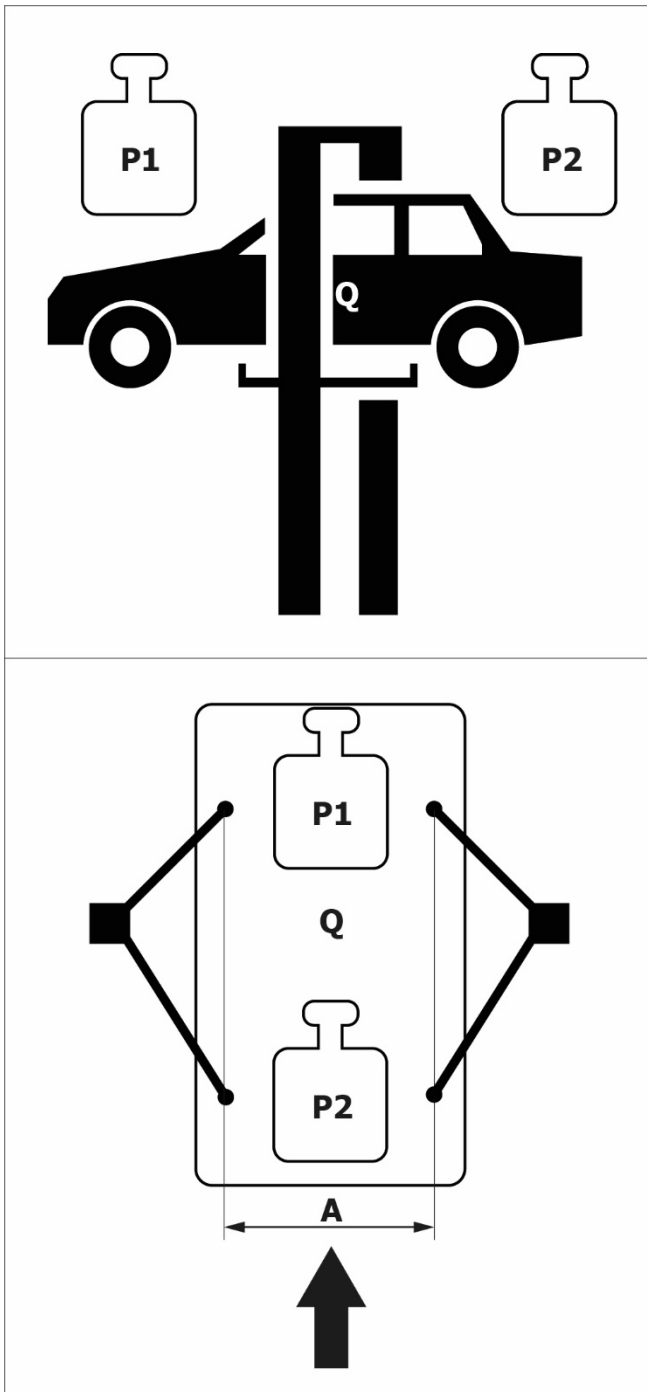

Q	Vehicle weight
P1	Max $3/5 \times Q$
P2	Max $2/5 \times Q$
Weight distribution	$2/3$
A^2	Min. 1.000 mm

²  **If the distance is less, the lifting capacity of the lift is reduced. In such and other cases that are not provided for in these instructions, please contact the manufacturer.**

1.5 Scale Drawing

Pure Lift 2.40

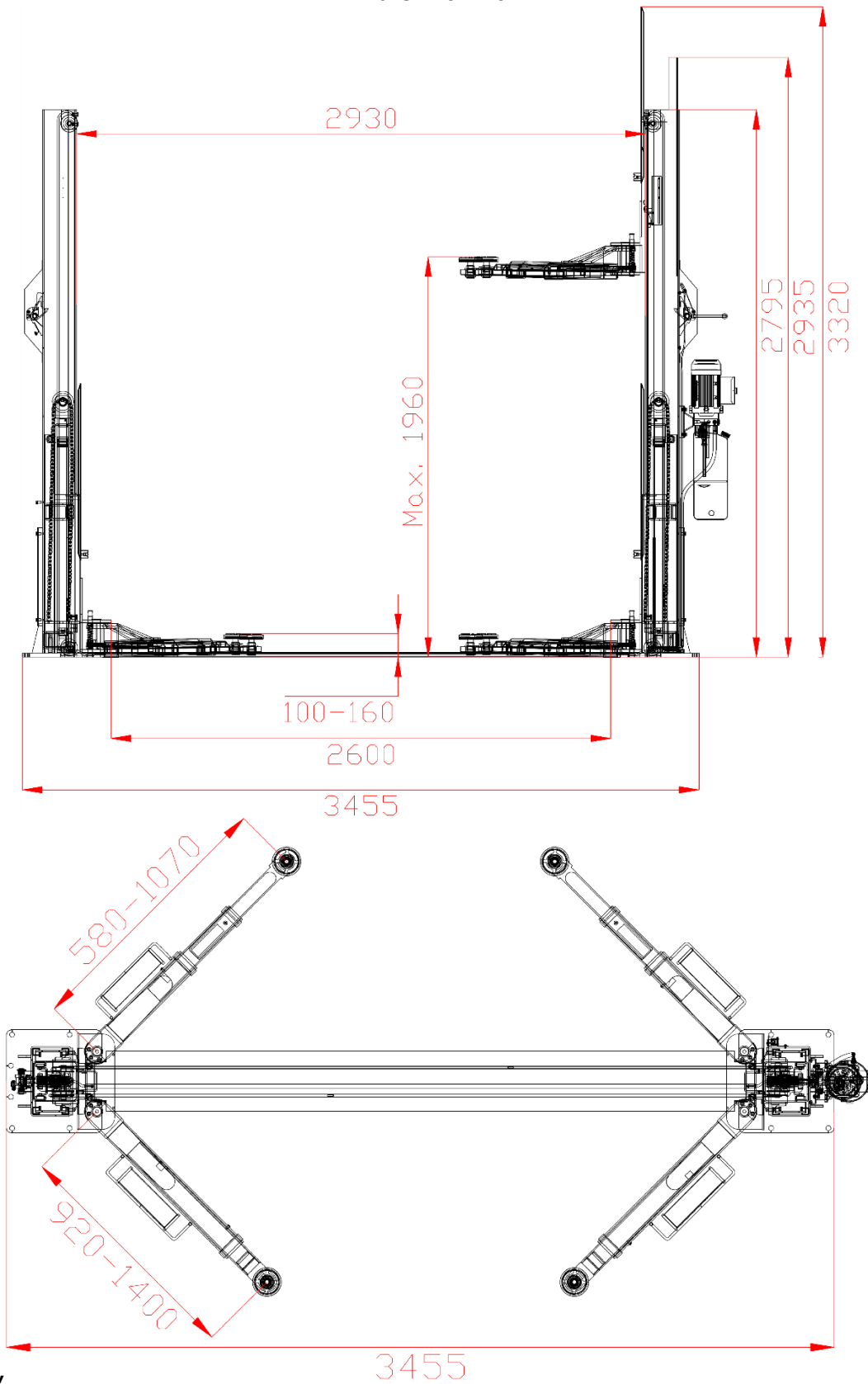

2.0 INSTALLATION

The machine must be installed by an authorised person according to the instructions.

	<p>The operating instructions (including the log) are an important part of the machine / product.</p> <p>!!!PLEASE STORE CAREFULLY!!!</p>
---	---

The product must be checked after completion of the installation, handover, if necessary briefing and then regularly in accordance with the applicable regulations and legal provisions in the country of operation by a suitable and approved company or facility.

2.1 Transport & Storage Conditions

When transporting and positioning the machine, always use suitable lifting and material handling equipment and consider the machine's centre of gravity.

The machine should only be transported with the original packaging.

Data:	See section 2.3 Delivery contents
Width	----
Length	----
Height	----
Storage temperature	-10 bis +50 °C

2.2 Unpacking the machine

	<p>Remove the top cover of the packaging and make sure that no damage has occurred during transport.</p> <p>Remove the safety bolt to remove the machine from the pallet / rack. Use a suitable lifting device (possibly with a stopping rope) to lower the machine from the pallet / frame.</p> <p>The packaging material used for the machine should be stored carefully. Keep the packaging material out of the reach of children as it may be hazardous.</p>
---	--

2.3 Delivery Contents

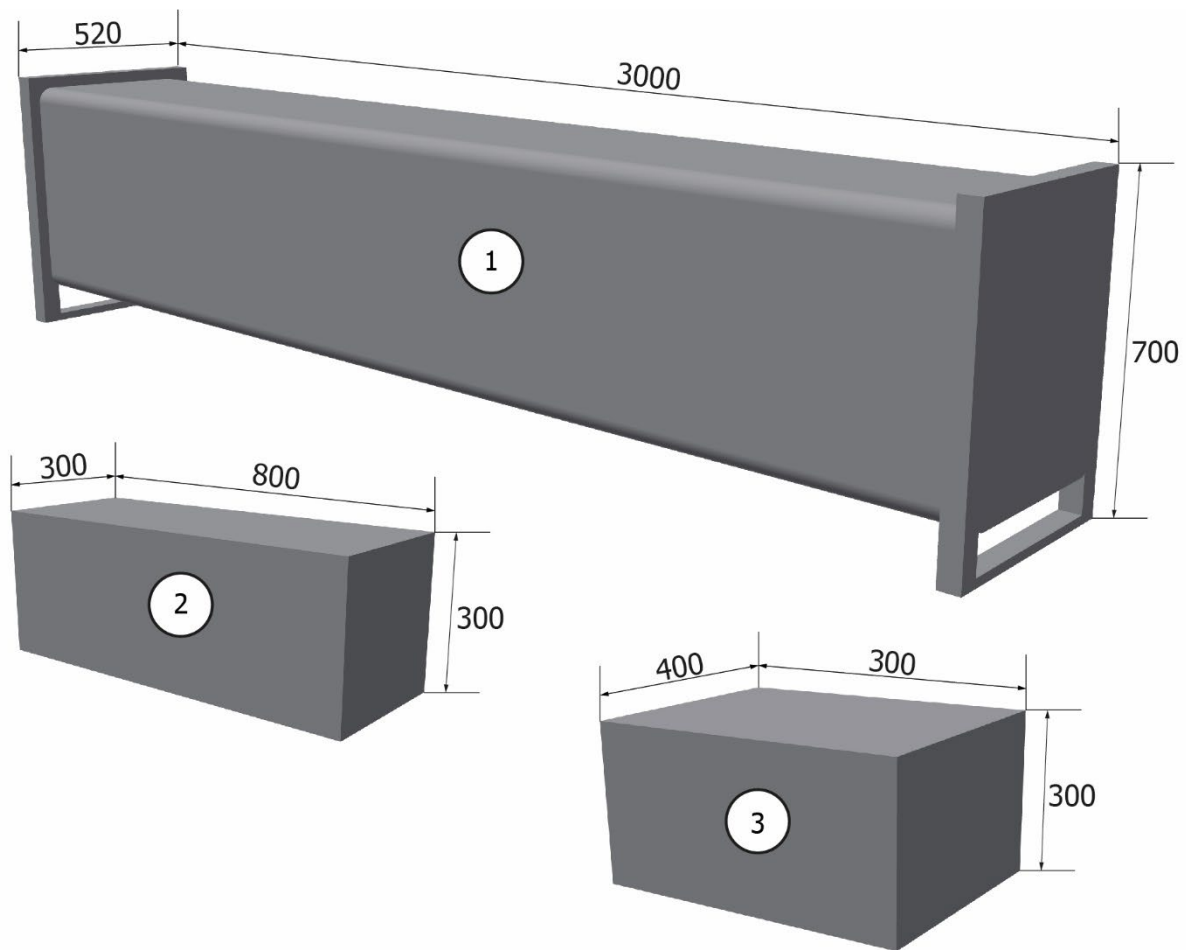

		Dimensions / weight
①	<ul style="list-style-type: none"> • Main column • Secondary column • Drive-over or cover protection with hydraulic hose • Operating instructions and the inspection book • Cover plate for carriage • Accessory box with: 4 lifting pads, 4 protective brackets for lifting arms, 2 safety locks, 2 plastic covers for safety locks, small parts 	3000 x 520 x 700mm 539 kg
②	<ul style="list-style-type: none"> • Hydraulic unit 	800 x 300 x 300mm 22 kg
③	<ul style="list-style-type: none"> • Control unit 	300 x 400 x 300mm 3 kg



If something is missing in the delivery, please contact your sales partner!

2.4 Location

The machine should be kept away from flammable and explosive materials, as well as from sunlight and intense light. The machine should be placed in a well-ventilated location.

The machine must be set up on sufficiently firm ground, if necessary, according to the minimum requirements of the information given in the foundation plan.

In addition to the ground conditions, the guidelines and instructions of the accident prevention regulations as well as the workplace regulations must be observed when selecting an installation site.

Based on a torn double steel-proven concrete slab made of C25 / 30 and should have a minimum thickness of 200 mm.

Max. Slope of 4 m	13mm
Concrete drying time:	Min. 20 Days

**⚠ Serious injury to personnel or damage to the elevator can result if the floors do not meet the requirements.
The operator is liable for the structural specifications and must ensure that the specifications and static requirements for installing the lift are guaranteed.**

When installing on floor ceilings, their sufficient load-bearing capacity must be checked. In general, it is advisable to consult a building expert for an assessment when installing on floor ceilings.

Distance between the column and the wall	Min. 800 mm
	Min. 3200mm
Permissible room temperatures:	-10/+50 °C
Maximum permissible humidity:	≤80% at 30 °C
Above sea level:	≤2000m
The mains connection and earthing cable (see technical data) must have a plug connection (socket and plug).	
Necessary electr. Connections and supply lines	See tech. data and may only be made by a specialist

The machine is only to be installed and used in closed rooms. It does not have any corresponding safety features for outdoor use (e.g. IP protection, galvanized design, etc.).

⚠ The lift is only designed for installation in dry rooms. Installation in wet rooms and rooms at risk of explosion is not permitted.

Drawing

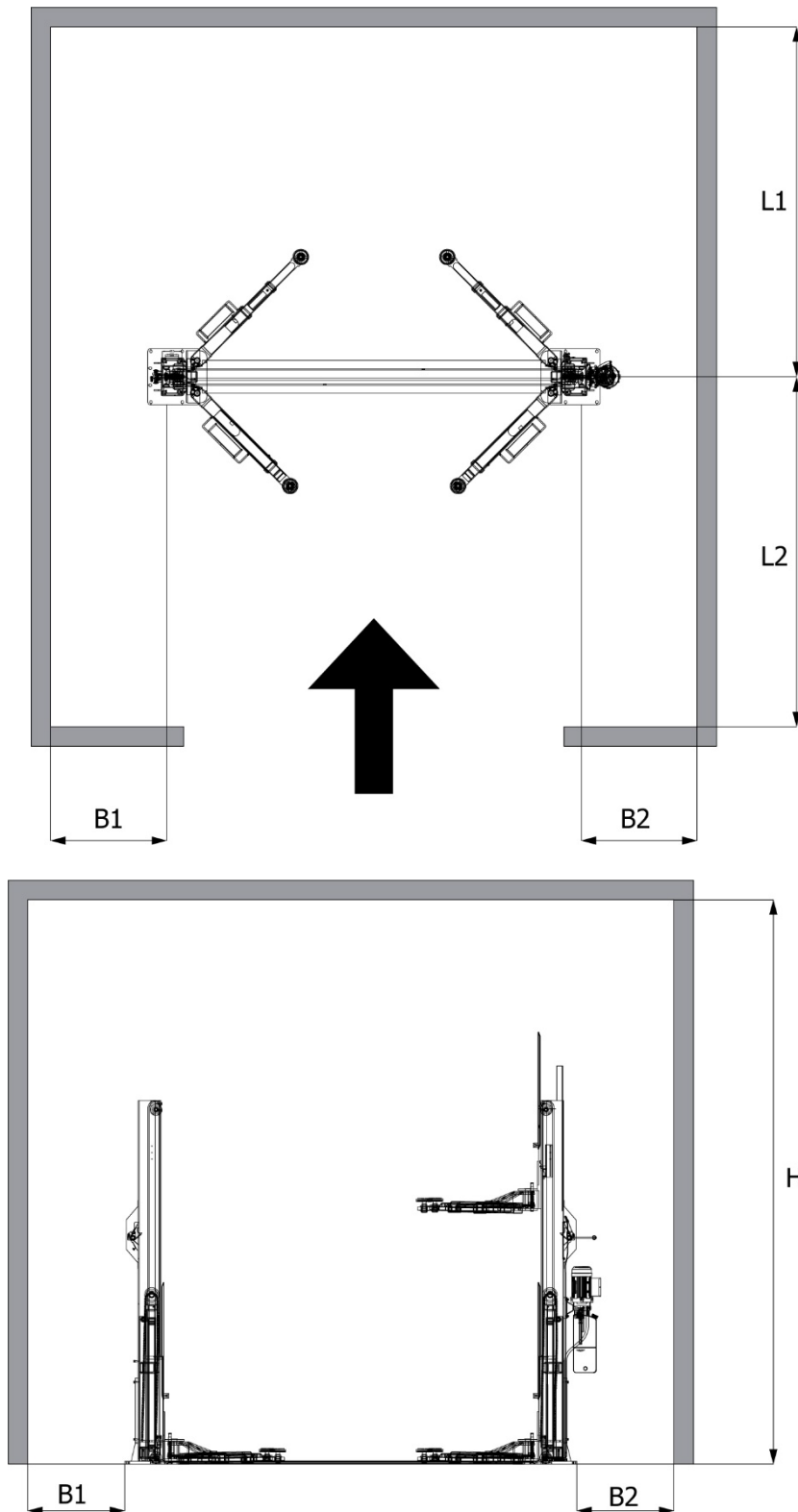

B1	Distance between the main column and the wall	Min. 1000mm	L1	Distance between pillars and wall	Min. 3200mm
B2	Distance between column and wall	Min. 700mm	L2	Distance between pillars and wall	Min. 3200mm
H	Required ceiling height	See technical data			

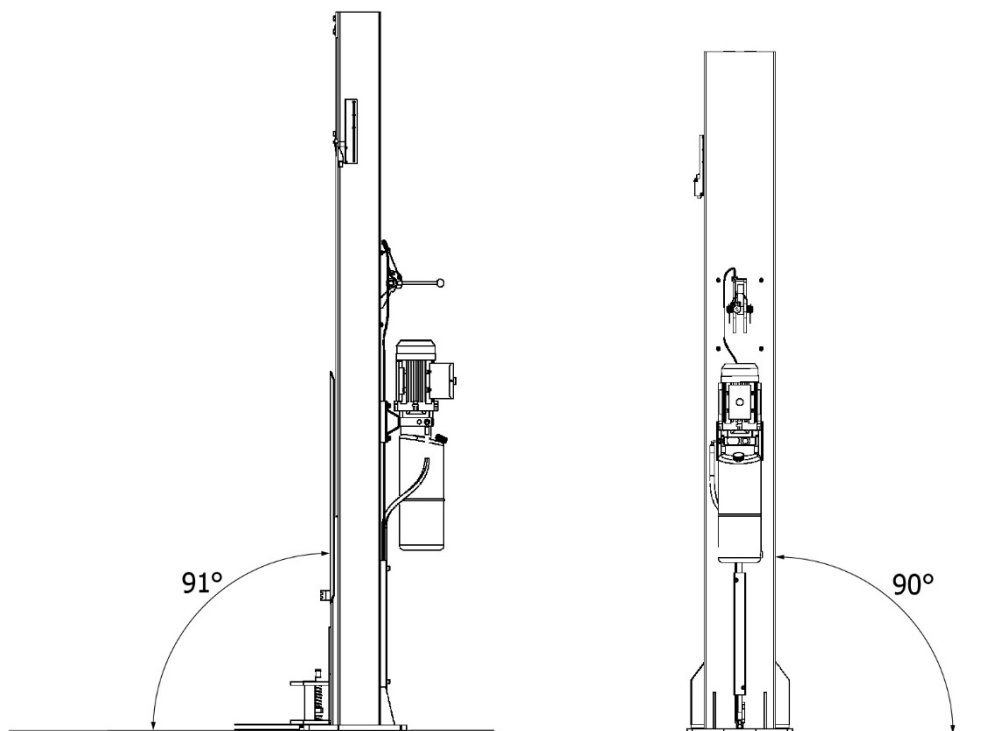

2.5 Fixing



General and local regulations must be observed. Therefore, these steps should only be carried out by a trained professional.

The machine must be set up and fixed on sufficiently firm ground, if necessary, according to the minimum requirements of the information given in the foundation plan.

The machine must be fastened at the points provided with suitable or specified fastening material.

In addition to the ground conditions, the guidelines and instructions of the accident prevention regulations as well as the workplace regulations must be observed when selecting an installation site.

When assembling on floor coverings, check their load-bearing capacity. A construction expert should be consulted for inspection when mounting on floor coverings.

2.6 Electrical Connection



General and local regulations must be observed. Therefore, these steps may only be carried out by a trained professional.
Pay attention to the necessary supply line (see technical data).

The connection should be made with a 230V Schuko plug or 5-pole 16 A CEE plug (partially included).

Voltage deviations should be 0.9 - 1.1 times the nominal voltage range and the frequency deviation should be 0.99 - 1.01 times the frequency range.

Necessary protective measures must be taken to guarantee this.

At the end of the work, the direction that the motor rotates (at 400V) must be checked.

2.7 Pneumatic Connection



For all pneumatic systems, a compressed air maintenance unit (partially included) must be installed between the supply line and the system.

The air pressure of the supply line must at least correspond to the technical data.

The compressed air maintenance unit must be set correctly and checked.

The compressed air maintenance unit must be serviced at regular intervals.

The maximum or minimum pressure ensures perfect functioning without any damage.

2.8 Hydraulic Connection



Before the system is put into operation or operated for the first time with oil, the following must be observed with regard to the optimal, trouble-free and almost air-free functioning

All hydraulic lines must be connected and tightened according to the hydraulic plan and, if applicable according to the hose designation.

All hydraulic lines and cylinders must be vented according to the hydraulic plan and, if applicable, according to the hose designation.

In order to ensure the faultless and safe functioning of the system and the hose assemblies used, the hydraulic fluids used must comply with the specific instructions and recommendations of the manufacturer.

Used media that do not meet the specific requirements or which have unauthorised contamination damage the entire hydraulic system and shorten the service life of the hydraulic systems used. Warning: (system contamination can also occur when oil is refilled)

The minimum requirement and minimum oil quantity must be checked and ensured.

2.9 Assembly



These instructions are not to be viewed as assembly instructions; hints and tips are provided only for trained expert installers. Suitable clothing and personal protection must be worn for the following work.
Incorrect installation and settings lead to exclusion of liability and warranty.

Partly pre-assembled machines must be checked, introduced and approved by a competent person before commissioning.

Machine assembly must be carried out by a qualified and competent person.

Foundation plan ATH-Pure Lift 2.40

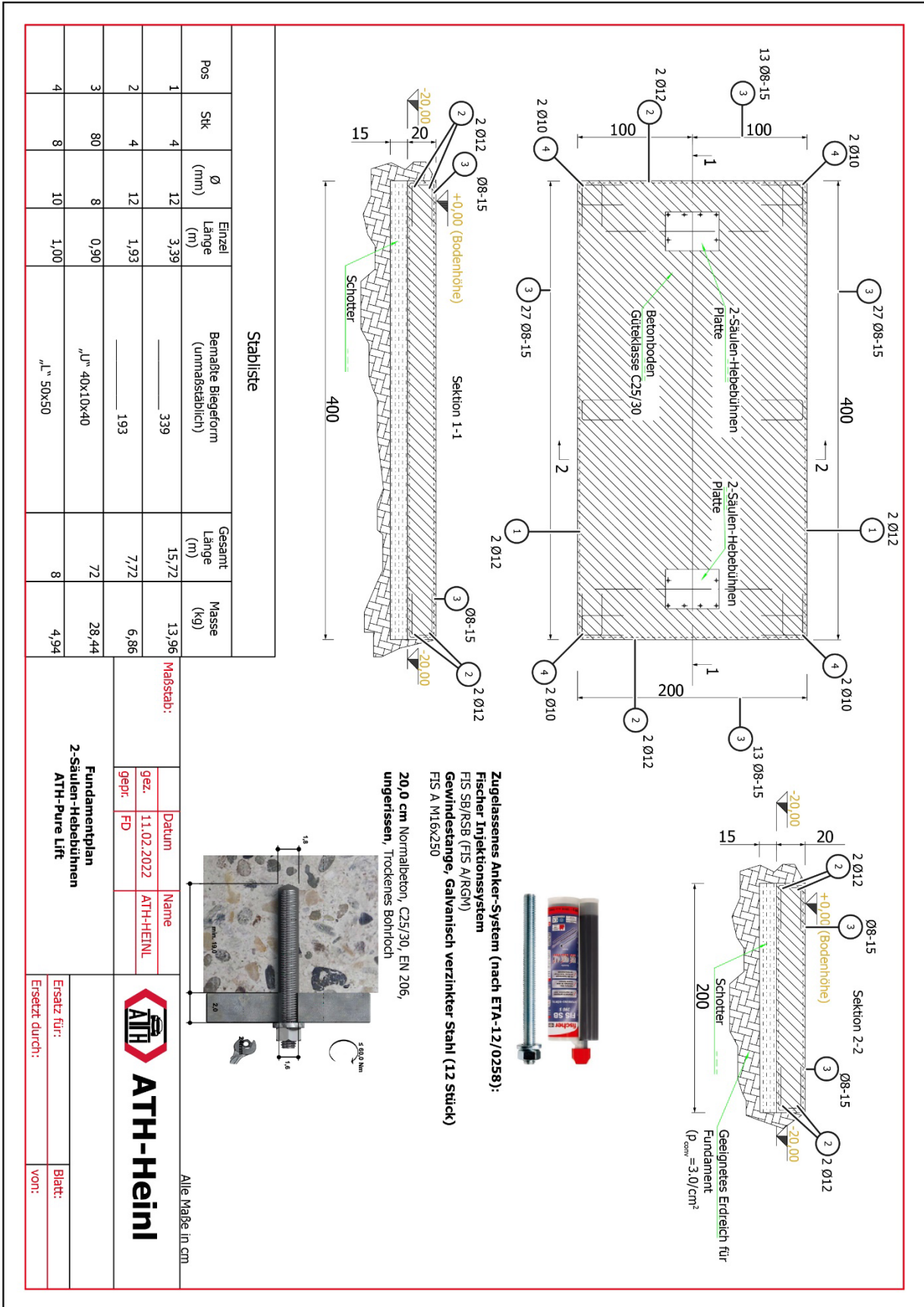

1. Fastening by means of safety anchors:

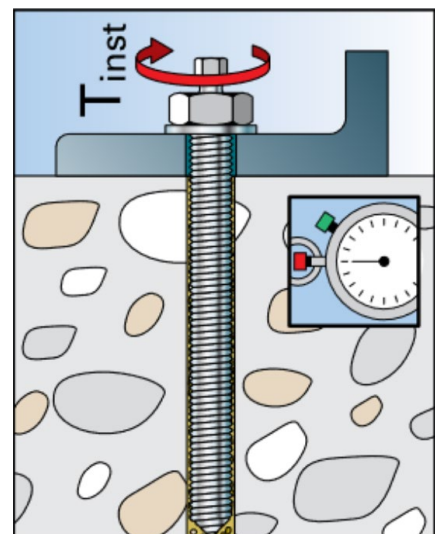
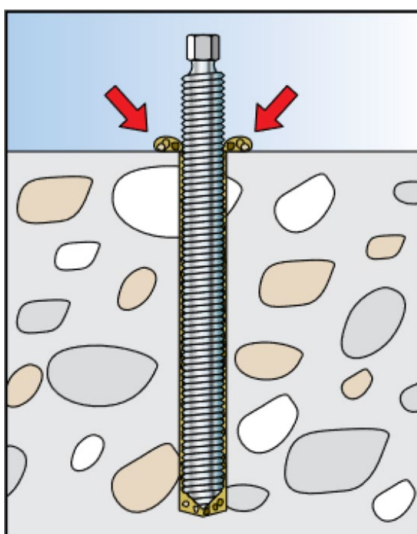
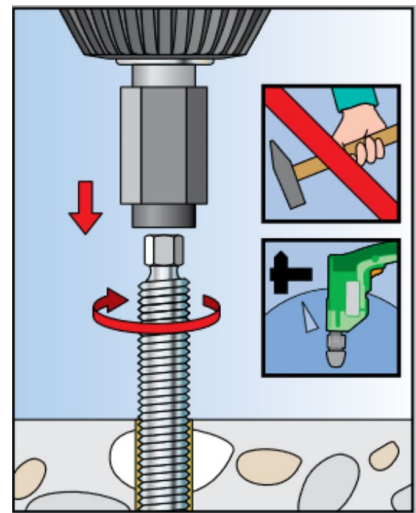
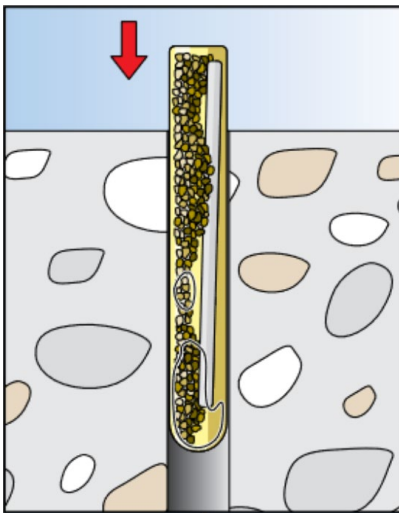
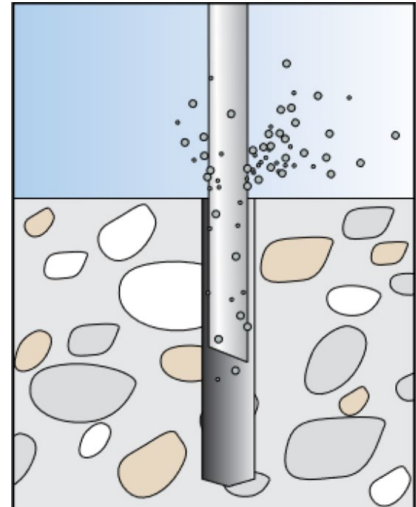
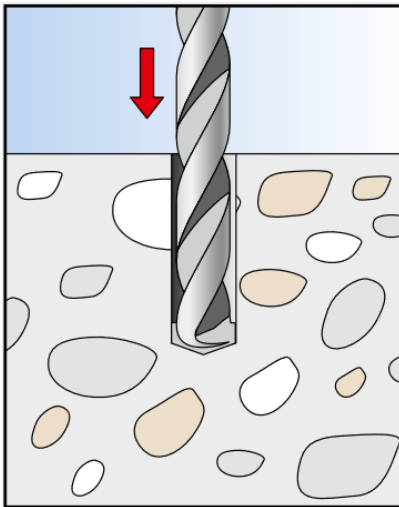

Lubricate the slideways of the columns

- a. Lubricate the slideways for the plastic blocks of the columns as shown in the following drawing.
- b. The applied grease is specified in the lubrication plan.

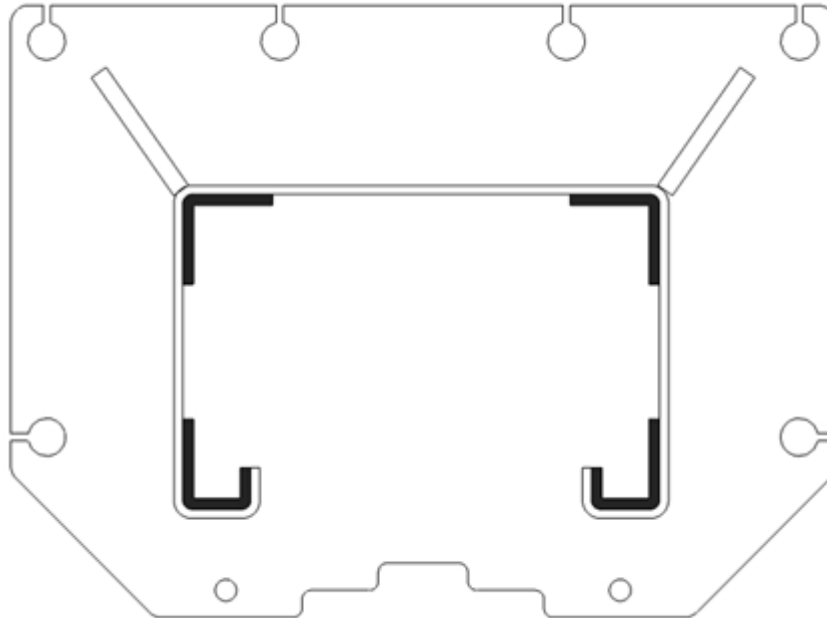

1. Lift the carriage into the notch
2. Assembly and adjustment of the Synchronization ropes
 - a. Mount the two Synchronization ropes at the bottom according to the specifications
 - b. Lubricate all pulleys and bolts, as well as plastic sliding pieces and their sliding surfaces in the columns
 - c. Tensioning and adjusting the Synchronization ropes. During the first presetting, the pallet trucks should be at the same height. The final setting should be made later with a weight (vehicle). Always firmly lock the lock nuts on the threaded adjustment bolts.
 - d. The Synchronization ropes are correctly adjusted when the notches snap into place at the same height when the lift is raised and when the lift is completely lowered, the two lift trucks are completely in contact with the bottom.



An adjustment of the synchronization ropes after a short operation time is eventually needed due to the material and does not mean that it is a warranty work but a maintenance work for which is the user responsible. This readjustment of the compensation ropes must be carried out by the operator with the recurring necessary control tasks and maintenance work.

Pure Lift 2.40

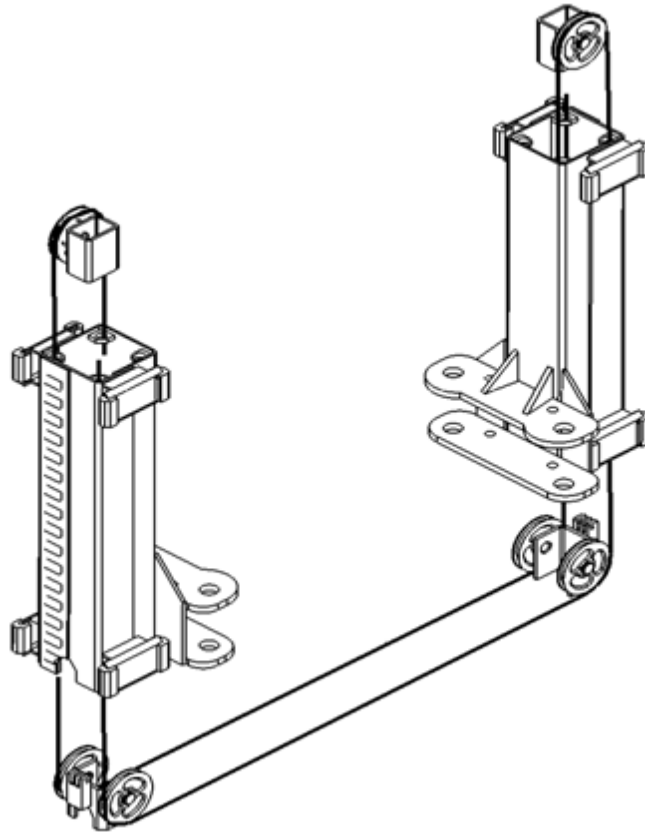

3. Mount the support arms
 - a. Install support arms and properly secure and lubricate the bolt.
 - b. When the support arm is fully extended, check that all stops are working properly, adjust if necessary.
 - c. Check support arm lock and adjust if necessary. Check for function when lowered.

4. Hydraulic oil
 - a. Fill hydraulic oil (see technical data) into the tank until the oil level has reached the mark on the dipstick.
 - b. There is air in the hydraulic circuit during commissioning. Move the lift up and down at least 10 times and make sure that there is sufficient hydraulic oil in the system. Carefully approach the upper limit switch the first time and check that it is working. Leave the cap of the tank open and top up with oil if necessary.

5. Electrical connection

 The electrical connection of the lift may only be carried out by a trained and authorized specialist. The local legal requirements, which may differ in the individual countries, must be complied with. Pay attention to the necessary specifications (see also technical data)

6. Checks before commissioning

- a. All screws, nuts, electrical and hydraulic connections etc. are tightened.
- b. Check all hydraulic connections and cylinders for leaks and tighten if necessary.
- c. Functional test of all electr. and mechanical components. Make sure that when you press the pushbutton or mech. Release lever release all safety catches.
- d. Check the support arm lock for proper function.
- e. Check the correct direction of rotation of the motor.
Raise and lower the lift 2 to 3 times and check the synchronization of the two pallet trucks.
- f. Lower the lift completely and hold the "LOWER" button pressed for approx. 15 seconds so that the hydraulic system is completely vented.



Important, check that the notches snap into place at the same height when starting up.

7. First lifting with a load

- a. Raise to approx. 1000 mm with a load (approx. 1500 kg).
- b. Check all parts and dowels.
- c. If the arms are not at the same height, readjust if necessary.
- d. When everything has been checked and is in order, move up and down at least 3 times.
Carefully approach the upper limit switch the first time and check that it is working.
- e. Check the support arm lock.
- f. Lower the lift and completely assemble all parts and covers.
- g. Finally fill the test book.



Only a careful and professional installation of the lift by a trained specialist ensures safe function and maintains the guarantee claims.











2.10 Theses



Before commissioning, check all fastening screws, electrical, pneumatic and hydraulic lines and, if necessary, tighten these. Warning: in some cases, this must be checked at regular intervals and tightened if necessary (note in the instructions).

3.0 OPERATION

3.1 Operating Instructions

Company: Job:	<h2>Operating instructions</h2> for working on vehicle lifts	Date: Signature:
         	Dangers for humans and the environment	
	<ul style="list-style-type: none"> • Danger due to a possible slipping of the vehicle • Danger from hot surfaces on the vehicle • Danger of crushing due to moving parts • Electrical hazards due to the electrical installations • Danger due to the lack of maintenance of the equipment 	
	Protective measures and rules of conduct	
	Lifting the vehicle <ul style="list-style-type: none"> • Position the vehicle on the lifting platform • Avoid uneven load distribution, do not overload the platform, use suitable pick-up elements with a non-slip or form-fit surface, only pick up at specified points on the vehicle • Check the function of the roll-off safety devices or the swivel arm safety devices in all directions • Lift only if no persons are endangered 	
	Work on the lifted vehicle <ul style="list-style-type: none"> • Depending on the work involved, select and wear personal protective equipment (e.g. hot surfaces) • Watch out for hot parts • Disassembly of components can change the load distribution: if necessary, secure vehicle against tipping • Use only approved mounting supports 	
	Lowering the vehicle <ul style="list-style-type: none"> • Remove tools and other objects from the danger zone • Lower only if no persons are endangered • Foot deflectors, gearshift strips or warning sound after intermediate stop prevent foot injuries 	
	The lifting platform may only be operated without supervision by instructed and competent employees aged 18 and over.	
	Behavior in the event of malfunctions and in the event of danger	
	<ul style="list-style-type: none"> • Report defects on the machine to the installer or manufacturer • Switch off the machine and secure it against unauthorized restarting • Have damage repaired by qualified personnel only • In case of fire, attempt to extinguish the fire 	
	First aid	
<ul style="list-style-type: none"> • Inform the first aider (see alarm or emergency plan) • Treat injuries immediately • Make entry in the dressing book • In case of serious injuries, make an emergency call 		
Maintenance		
<ul style="list-style-type: none"> • Repair only by authorized and instructed persons • Disconnect or secure the machine from the power supply during setup, adjustment, maintenance and servicing work • Clean the lifting platform at the end of work and check the level of the hydraulic system • Annual check of the lifting platform by an authorized and instructed person 		

Emergency
112

3.2 Basic Information

Independent operation of the machine may only be carried out by persons over the age of 18 who have been trained in the operation of the machine and have demonstrated their ability to do so to the employer. They must be expressly contracted by the employer to operate the machine. The order to operate the machine must be given in writing.

The machine must only be used for its intended use.

Always use appropriate material during installation and operation.



Before assembly or disassembly check all components for damage.

If necessary, observe special manufacturer instructions for mounting or dismounting of vehicle-specific work.

An important part of the guarantee / warranty is fulfilment of the maintenance plan. This includes in particular, ensuring cleanliness, corrosion protection, checks and repairing damages immediately if required.

During operation attention should always be paid to hazards. As soon as dangers occur, switch off the machine immediately, remove the mains plug and disconnect the air supply. Then contact your dealer.

All warning labels must always be easy to read. If damaged, they must be replaced immediately.

	<p>Pay attention to possible shearing points around the machine.</p>
	<p>During operation, the noise can reach 85dB (A), so the operator should take appropriate protective measures.</p>
	<p>Moving parts of the machine can catch loose clothing, long hair or jewellery.</p>

This product is designed exclusively for lifting suitable vehicles. The relevant technical specifications of the lift must be observed.

Preparation

 READ AND OBSERVE the safety instructions, operating instructions and statutory BG requirements.

- Lower the lift completely.
- Set the support arms parallel in the approach direction.
- Drive the vehicle in the center of the lift so that the arms can be swiveled to the vehicle mounting points. If necessary, roll the vehicle forwards or backwards.
- Pay attention to the given weight distribution.

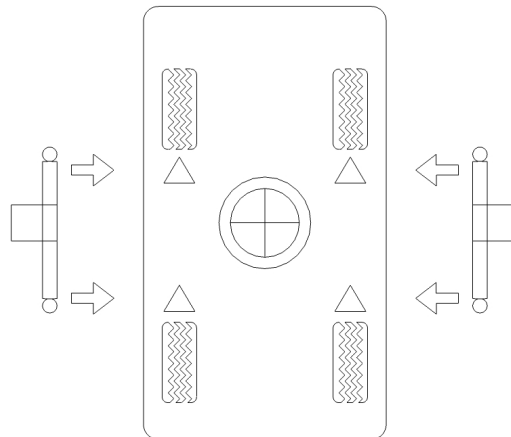

- Swivel the support arm under the vehicle to the specified position and unscrew the support plate until it lightly touches the mounting point. A lifting plate may be necessary for various vehicles. Use only one increase per plate.
- With the multi-part support arms, all parts should be pulled out evenly. This is the only way to ensure an even load on the lift.

 **Maximum support plate increase $H = 200$ mm. Use only one-piece elevations.**

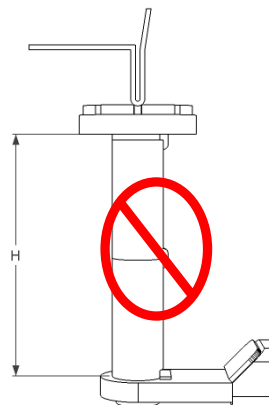

Lifting the vehicle

- Raise the vehicle slightly (without the wheels lifting off the ground) by pressing the "Lift" button and check that all carrier plates are correctly positioned. Readjust if necessary.
- See brief operating instructions
Raise the car to a height of 100-150mm and stop lifting by releasing the lift button
- Check that the car is safely on the lift and that the arm lock is activated.
- Then continue to lift and observe the lifting process.

LOWER the lift

- Before LOWERING, check that there are no people or objects under the vehicle or the carrying arms.
- LIFT the lift approx. 4 cm so that you are sure that the lift truck is not in the safety catch.
- Then first actuate the release lever for the safety catches and then actuate the lowering lever of the hydraulic unit and keep it actuated until the lowering process is finished. While lowering the vehicle, keep an eye on the vehicle; if you make a mistake, release the lever immediately.

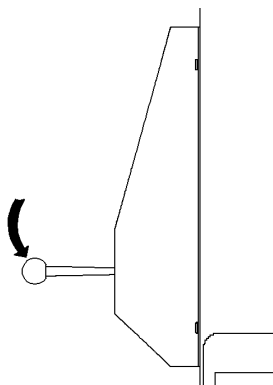

Release lever for the safety catches

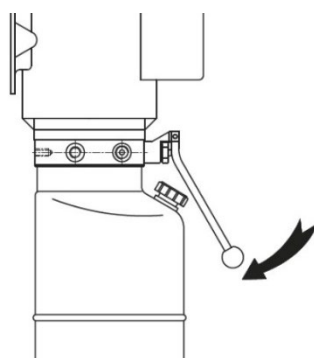

Lowering lever of the hydraulic unit



Completion

- Lower the platform completely.
- TURN the support plate down and swivel the support arms back into the 90 ° position.
- Drive out the vehicle.

4.0 MAINTENANCE

The user must maintain the machine regularly to ensure safe operation.

Repair work may only be carried out by authorised service partners or after customer consultation with the manufacturer.

	<p>Before maintenance and repair work:</p> <ul style="list-style-type: none"> - The machine must be disconnected from ALL supply networks - Pull main switch out of mains plug, if necessary, discharge compressed air from system - Appropriate measures must be taken against a restart
	<p>Work on electrical elements or on the supply line may only be carried out by experts or electricians.</p>

4.1 Consumables for installation, maintenance and servicing

Hydraulic Oil

General minimum requirement:

Eni PRECIS HVLP-D Item No. 00066018

Summer (15° to 45°): HVLP-D 46 (e.g.: Eni PRECIS HVLP-D)

Winter (under 10°): HVLP-D 32 (e.g.: Eni PRECIS HVLP-D)

Minimum requirement **especially for 2-post lifts:**

Eni PRECIS HVLP-D Item No. 00067218

Summer (15° to 45°): HVLP-D 32 (e.g.: Eni PRECIS HVLP-D)

Winter (under 10°): HVLP-D 22 (e.g.: Eni PRECIS HVLP-D)

Preservative for ropes, welds, screws, corners, edges and cavities.

Minimum requirement:

Petec spray translucent - 500 ml Item No. 73550 / Petec wall inlet translucent - 1000 ml Item No. 73510

Petec UBS pistol Item No. 98507

Slideway lubricant

Minimum requirement:

STORER WHS 2002 White EP high performance grease. Item No. KPF1-2K-20

Lubricant for bushes, chains, rollers & moving parts

Minimum requirement:

White ultra lube, 500 ml aerosol. Item No. 34403 – WUL – White Ultra Lube

Floor anchor

Minimum requirement **for lifting platforms:**

Fischer FIS A M 16 x 250 galvanised in combination with Fischer Superbond reaction cartridge

Minimum requirement for **passenger car and passenger car/truck balancing machine:**

Impact anchor M8 x 100

Minimum requirement **for truck mounting machine:**

Impact anchor M12 x 100

Compressed air system

Minimum requirement:

PROMAT chemicals special compressed air oil Item No.: 4000355209

Cleaning

Minimum requirement:

Caramba intensive brake cleaner acetone-free

Care and protection of metals, painted or powder-coated surfaces

Minimum requirement:

Petec spray translucent - 500 ml Item No. 73550

Petec wall inlet translucent - 1000 ml Item No. 73510

Petec UBS pistol Item No. 98507

Care and protection of metals, painted or powder-coated surfaces in the tread area and plastic parts

Minimum requirement:

Valet Pro Classic Protectant Plastic Sealant 500 ml

4.2 Safety Regulations for Oil

Always observe the legal requirements or regulations for handling used oil.

Always dispose of used oil through a certified organisation.

In the case of leaks, oil must be collected immediately with binders or trays so that it cannot penetrate into the soil.

Avoid any skin contact with the oil.

Do not allow oil vapours to escape into the atmosphere.

Oil is a combustible medium. Pay attention to possible hazards.

Wear oil-resistant protective clothing, such as gloves, goggles, protective clothing, etc.

4.3 Notes

	<p>Regardless of the level of dirt, the machine must be maintained, cleaned and serviced at regular intervals.</p> <p>The machine should then be treated with a care product (such as oil or wax spray). Do not use cleaning agents that are harmful to the skin.</p> <p>IF THE ABOVEMENTIONED POINTS ARE NOT FULFILLED, THE WARRANTY CLAIM IS EXCLUDED</p>
---	--

4.4 Maintenance or Service Plan

Interval	Immediately	Weekly	Monthly	Every 3 months	Every 6 months
Check of ALL safety-relevant parts	X				
Cleaning	X				
Check or restore surface protection	X				
Check for leaks in the hydraulic system	X				
Check or restore surface protection or corrosion protection	X				
Check or restore damage to the paint and components	X				
Check or restore rust damage	X				
Check or treat cavities and non-painted areas	X				
Check for leaks in the pneumatic system	X				
Control the tightness of screws	X				
Check, lubricate & adjust bearing slack	X				
Check wear parts		X			
Check fluids (level, wear, contamination, quality)		X			
Check and lubricate sliding surfaces		X			
Remove any dirt inside			X		
Clean and check electrical components				X	
Check motor and transmission for function and wear				X	
Check welds and construction				X	
Visual inspection (according to inspection plan)					X

Maintenance schedule

Inspection period:	Components:	Exam on:
Daily	Pick-up plate	Wear and deformation
	Synchronizing ropes	Tension, damage
	Lifting platform	Obvious damage
	Lifting platform	cleanliness
	Lifting chain	Obvious damage
	Hydraulics	Tightness
	Safety devices	Obvious damage
Weekly	Magnets	Function and wear
	cylinder	wear and tear
Monthly	Anchor bolts	Torque (according to dowel manufacturer)
Quarterly	Axles of the pulleys and safety notches	Clean
	Bolts for lifting chain	wear and tear
	Lifting chain	Wear and deformation
	Synchronizing ropes	wear and tear
	Support arm lock	Function and cleaning
	Cylinder (dust seal)	Wear and deformation
Half a year	Electronic Components	Damage
	oil level	Scarcity
Yearly	Cylinder seal	Loss of oil and deformation
	poor	Wear and stop
Every 3 years (Recommended)	Hydraulic oil	Change
	Hydraulic system	cleaning
Every 6 years	Hoses	exchange

Lubrication plan

Inspection period:	Components:	Type of oil or fat
Monthly	Lifting chain	Chain spray
	Bolts for lifting chain	Multipurpose grease
	Slideways	Multipurpose grease
Quarterly	Synchronizing ropes	Adhesive grease
	Support arm lock	Lubricate
	Axles of the pulleys and safety notches	Multipurpose grease

Maintenance and service instructions

Oil level check

1. Lower the lift completely
2. Remove the tank cap
3. Check the oil level on the tank cap

Oil change

1. Lower the lift completely
2. Remove the oil filler plug
3. Carefully remove the oil drain plug and allow the oil to flow into a suitable container.



Clean the tank and oil filter to avoid premature contamination of the hydraulic oil.

4. After the oil has been completely drained, close the tank with the oil drain plug
5. Fill the new oil into the oil tank
6. Raise and lower the lift and check that the maximum lift height is still correct. Refill carefully if necessary.

The used oil must be disposed of in compliance with all statutory provisions.

Bleeding the hydraulic system

1. Lower the lift completely.
2. Press the lower button and simultaneously press the two lifting pistons down to the minimum.

Adjust synchronization ropes



In order to check the synchronism, you can hear the click of the safety notches, the pallet truck, which clicks later, has to be tightened.

1. Raise the lift to a height of approx. 100-200 mm.
2. Remove the column tape.
3. Slightly loosen the lock nut.
4. Tension the pull rope using an open-ended wrench.
5. Tighten the lock nut again.

Control of the synchronizing ropes

Explanation of the components:

- A = steel cable
- B = deposit
- C = stranded wire
- D = wire
- E = central strand
- F = section

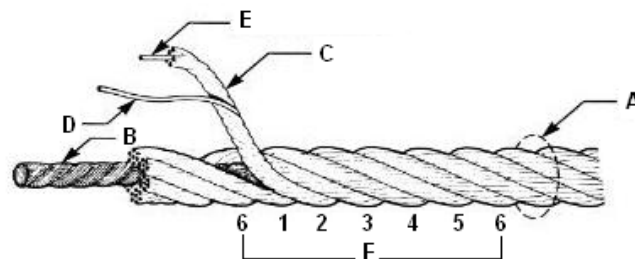

The synchronous rope must be replaced if the following reasons apply:

1. 6 wires within a section are defective
2. 3 wires of a stranded wire within a section are defective
3. Rust damage to ropes or connections
4. Kinks, bruises, heat damage or a broken insert
5. A wear of 10% of the original diameter

4.5 Troubleshooting / Error Display and Solutions

Symptoms	root cause	Solution
Problems lifting		
The lift does not raise when the button is pressed (motor not running)	Damage to the engine	Check motor, replace if necessary
	Blown fuses, e.g. due to voltage fluctuations	Eliminate causes and replace fuses
	Defective button and / or contact	Replace button and / or contact
	Defective main switch and / or contact	Replace main switch and / or contact
	Defective or insufficient supply line	Replace cable
	Fluctuating or incorrect input voltage	Check tension
	Defective motor contactor	Replace motor contactor
	Thermal relay has triggered	Check thermal relay and motor
	Limit switch defective or blocked	Check limit switch, replace if necessary
Lift does not raise when button is pressed (motor is running)	Lack of hydraulic oil	refill oil
	Oil filter clogged	Clean the oil filter
	Oil loss	Replacement of the damaged components
	Opened lowering valve	Check and replace the lowering valve if necessary
	Wrong direction of rotation of the motor	Swap phases
	Defective gear pump	Check the pump and replace it if necessary
	Permissible load has been exceeded	Work within the specified load
	Pressure relief valve set too low	Set the pressure relief valve to maximum load
Lift jerks up	too little space between slide rails	The distance between the slide rails and the guide must be 1.5 - 2.5 mm
	Air in the hydraulic system	Bleed the hydraulic system
	Contaminated hydraulic oil	Change the hydraulic oil
	Slideways are not lubricated	Lubricate the slideways
The lift continues to raise after releasing the button	Defective button	Replace the defective button

Problems with lowering		
The lift does not lower	Safety notches do not respond	Check cable connection
	Defective control relay	Check electromagnet, replace if necessary
	Obstacle under stage	Relieve resting by lifting
	Hose rupture protection triggered	Check control relay
	Lowering valve is not activated	Remove obstruction
	The lowering valve solenoid is defective	Briefly raise the platform and press "DOWN" again
	Lowering valve defective	Check electrical connection
	Lowering speed valve incorrectly set	Replace solenoid
If the fault cannot be rectified, lower the lift using the emergency lowering screw and contact our service team		
Stage lowers too slowly or jerkily	Dirty lowering valve	Clean the lowering valve
	Lowering speed valve incorrectly set	To adjust
The lift lowers by itself	Leaking hydraulic connections	Retighten connections, seal if necessary
	Leaking hydraulic lines	Replace hydraulic line
	Leaking hydraulic cylinders	Replace seals and clean the hydraulic system
	Dirty or defective lowering valve	Clean or replace the lowering valve
	Leaking check valve	Clean or replace
Other problems		
The lift does not raise and lower synchronously	Air in the hydraulic circuit	Vent the hydraulic circuit
	Insufficient tension in the synchronizing ropes	Setting the voltage or the synchronization
Product shows (severe) rust damage	Damage or inadequate corrosion protection, maintenance if necessary	De-rust, clean and restore the surface.
unusual volume of the engine	Oil filter contaminated	Clean the oil filter
	Air in the hydraulic circuit	Bleed the hydraulic system
	Contaminated hydraulic oil	Change the hydraulic oil
Circuit breaker has been activated	Check the contact on the contactor	Replace the contactor
	Checking the capacity of circuit breakers	Replace the fuses
	Check for damage to the cable	Replace the cable
ALWAYS MAKE SURE YOU USE GENUINE PARTS AND ACCESSORIES.		

4.6 Maintenance and Service Instructions



All maintenance and service work should be carried out at least according to the maintenance schedule

COMPRESSED AIR MAINTENANCE UNIT (Partial stock if necessary for the activity)

SETTING THE WORKING PRESSURE:

- Check the working pressure displayed by the manometer (1). This must correspond to the technical data.
- The working pressure can be adjusted with a pressure regulator (A).
- Pull the pressure regulator upwards to make adjustments.
- Turn the knob clockwise to increase the pressure in the machine, turn it counter clockwise to decrease.

OILER

- Check the oil level in the oil reservoir (3).
- Remove the oil reservoir.
- Now refill the tank with a pneumatic oil with a viscosity of SAE20.
- Check the injection quantity of the oil through the viewing glass (4).
- Generally, the screw must be closed completely in a clockwise direction and then opened again about $\frac{1}{4}$ to $\frac{1}{2}$ turn by turning it counter clockwise.

WATER SEPARATOR

- Check the water level in the separator (2).
- Water is drained when the valve (B) is opened.

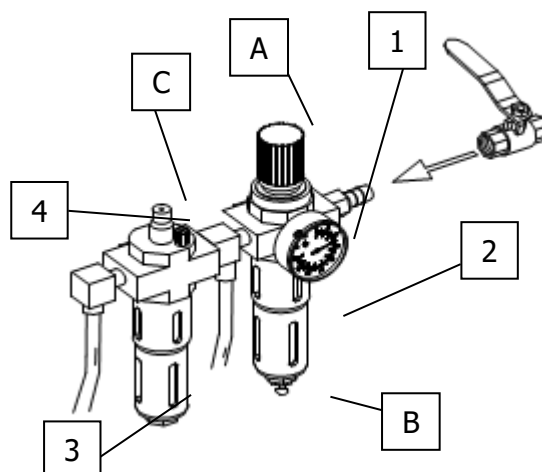

4.7 Disposal

- Remove the air and power supply.
- Remove all non-metallic substances and store them in accordance with local regulations.
- Remove the oil from the machine and store it in accordance with local regulations.
- Recycle all metallic substances.

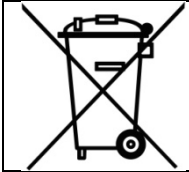

The machine contains some substances that can pollute the environment and cause harm to the human body if not handled correctly.

5.0 EG-/EU-KONFORMITÄTSERKLÄRUNG / EC-/EU-DECLARATION OF CONFORMITY

gemäß Maschinenrichtlinie 2006/42/EG, Anhang II 1A, EMV-Richtlinie 2014/30/EU, Anh. IV
In accordance to Machine Directive 2006/42/EG, Appendix II 1A, EMC Directive 2014/30/EU, App. IV

Seriennummer / Serial number:

**Konformitätserklärung
Declaration of conformity**



Für / for

Typ / Type

KFZ-Hebebühne
Car-lift

**Zweisäulenhebebühne/Two Post Lift
ATH-Pure Lift 2.40 230V / ATH Pure Lift 2.40 400V**

Wurden folgende einschlägige Bestimmungen beachtet
The following EG-directives are considered

2006/42/EC (Machine-Directive)

Folgende harmonisierten Normen und Vorschriften wurden
eingehalten
The following harmonized standards are applied

**DIN EN 1493:2010 (Machine-Directive)
DIN EN 60204-1: 2006+A1:2009 (Low voltage directive)-Part 1 :
General Requirements**

Hersteller
Manufacturer

**ATH-Heinl GmbH &Co. KG
Kauerhofer Straße 2
D-92237 Sulzbach-Rosenberg
Germany**

Prüfinstitut
Institut of Quality

**CEM International Ltd
The Atrium Business Centre Curtis
Road Dorking Surrey RH4 1XA UK**

Referenznummer der technischen Daten:
Reference number for the technical data:

F-20-1106-13-01-B

Herstellerbezeichnung
Designation of producer

(201311001);

Nummer des Zertifikats:
Number of the certificate:

C-20-1106-13-01-B-M

Hiermit wird bestätigt, dass die oben bezeichneten Maschinen den genannten EG-Richtlinien entsprechen.
Herewith we confirm that the above named machines are according to the named EC-directives.

**ATH-Heinl GmbH &Co. KG
Kauerhofer Straße 2
D-92237 Sulzbach-Rosenberg
Germany
Im Dezember 2011**

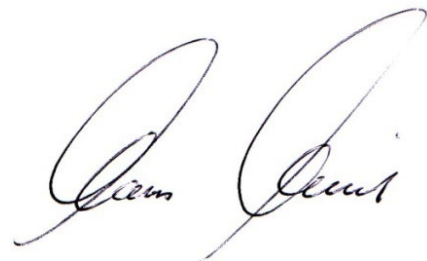

ATH-Heinl GmbH & Co. KG/ Hans Heinl (Geschäftsführer)

6.0 APPENDIX

6.1 Pneumatic circuit diagram Not relevant!

6.2 Electric circuit diagram

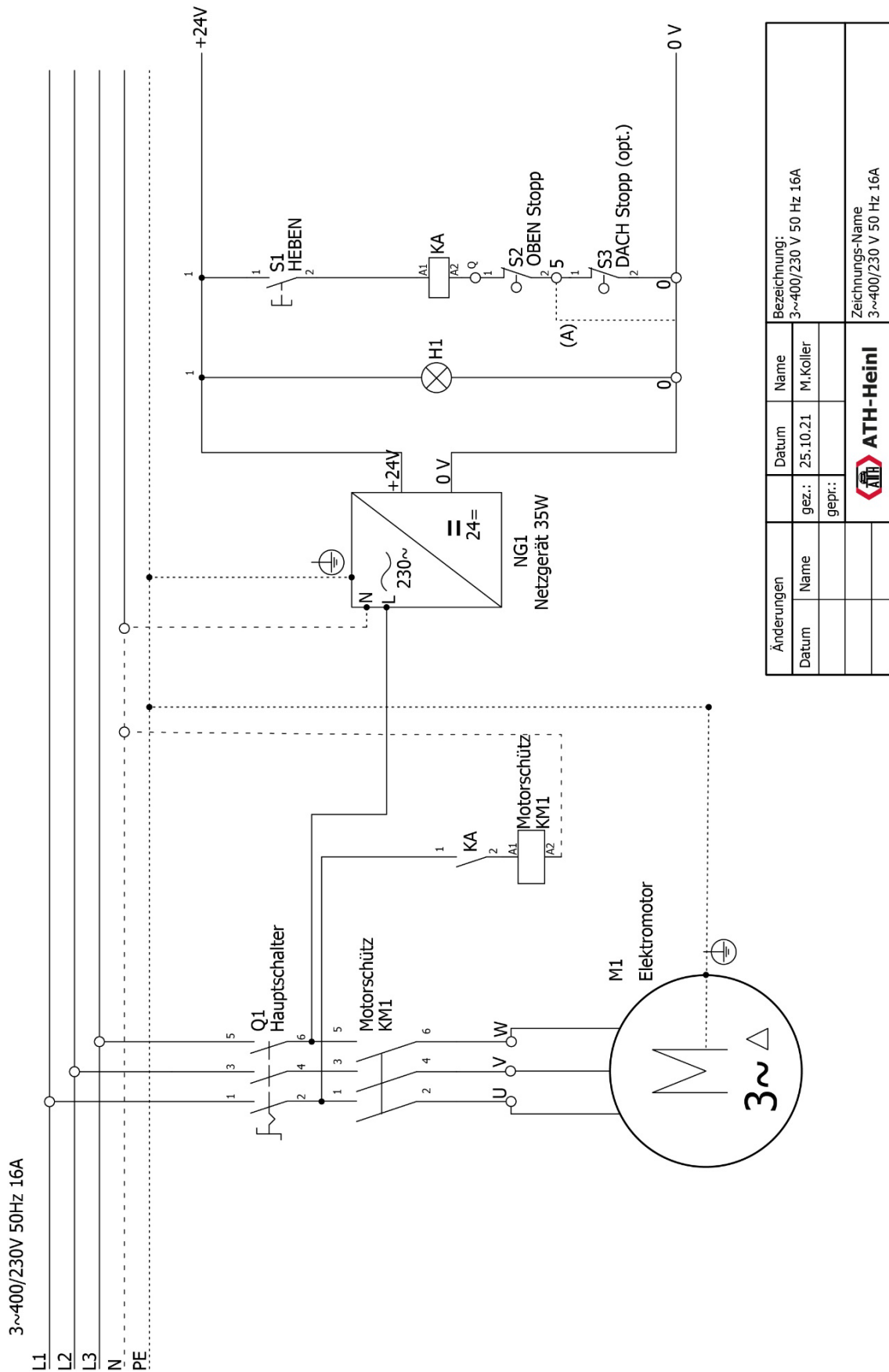

6.3 Hydraulic circuit diagram

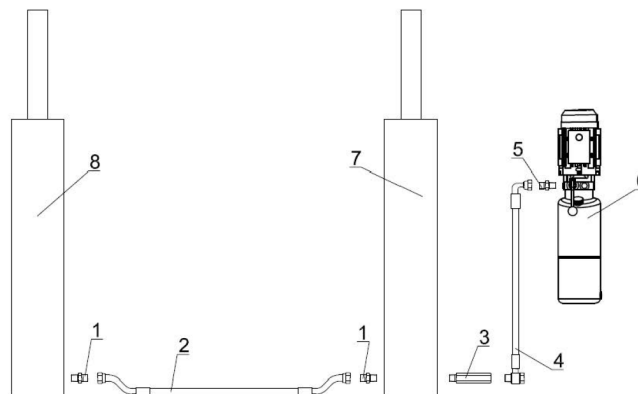

1	Connection cylinder inside	5	Connection unit
2	Hydraulic hose cyl-cyl	6	Hydraulic power pack
3	Connection cylinder outside	7	Master cylinder
4	Hydraulic hose cyl	8	Follow cylinder

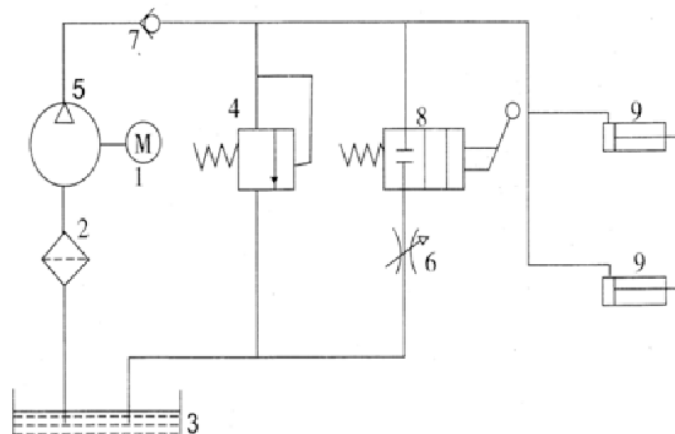

1	engine	6	Lowering speed valve
2	filter	7	check valve
3	Oil tank	8	Mechanical lowering valve
4	Pressure relief valve	9	Hydraulic cylinder
5	Gear pump		

7.0 WARRANTY CARD

Dealer address:	Customer address:		
Company (or customer number):	Company (or customer number):		
Contact partner:	Contact partner:		
Street:	Street:		
Postcode & town:	Postcode & town:		
Tel. & Fax:	Tel. & Fax:		
Email:	Email:		
Manufacturer & model:	Serial number:	Year of construction:	Reference number:

Message description:

Description of required spare parts:		
Spare part:	Item number:	Amount:

IMPORTANT:

Damage resulting from improper handling, lack of maintenance or mechanical damage is not covered by the warranty. For systems that have not been installed by an ATH approved installer, the warranty is limited to the provision of the necessary spare parts.

Transport damages:

Visible defect (visible transport damage, note on freight forwarder delivery note, immediately send copy of the delivery note and photos to ATH-Heinl)

Hidden defect (transport damage is only detected when unpacking the goods, send damage report with pictures to ATH-Heinl within 24 hours)

Place & Date

Signature & Stamp

7.1 Scope of the Product Warranty

- Five years for the devices structure
- Power supplies, hydraulic cylinders and all other wear components such as turntables, rubber plates, ropes, chains, valves, switches, etc., are limited to one year under normal circumstances/use under warranty conditions.

The warranty does not extend to:

- Defects caused by normal wear and tear, misuse, transport damage, improper installation, tension or lack of required maintenance.
- Damage caused by neglect or failure to follow the instructions in this manual and/or other accompanying instructions.
- Normal wear and tear on parts requiring service to keep the product in safe working condition.
- Any component that has been damaged during transport.
- Other components that have not been explicitly listed but are considered to be general consumables.
- Water damage caused by e.g. rain, excessive humidity, corrosive environments or other contaminants.
- Blemishes that do not affect function.

**WARRANTY IS NOT VALID,
IF THE WARRANTY CARD WAS NOT SENT TO ATH-HEINL.**

Damage and malfunctions caused by non-compliance with maintenance and adjustment work (according to operating instructions and/or training), faulty electrical connections (rotating field, rated voltage, protection) or improper use (overload, outdoor installation, technical changes) are excluded from the warranty!

8.0 INSPECTION LOG

	<p>This inspection manual (including log) is an important part of the operating instructions and product.</p> <p>!!!PLEASE STORE CAREFULLY!!!</p>
---	---

Check

The product must be checked after completion of the installation, handover, if necessary briefing and then regularly in accordance with the applicable regulations and legal provisions in the country of operation by a suitable and approved company or facility.

In the case of changes or extensions to the product type, an additional inspection book must be maintained and accepted.

Scope of Inspection



In addition to perfect function, cleanliness and maintenance requirements, it is vital that the safety-relevant components of the entire system are checked.

Technical Data

- Please refer to the enclosed operating instructions.

Nameplate

- Make a note of all the data below
- Manufacturer & type of mounting materials used:

 ATH-Heinl	
Typ Type	Volt
Serien # Serial #	Ph
Baujahr Year of built	Hz
	Amp.
	kW
 	Designed by ATH-Heinl Germany Manufactured in China ATH-Heinl GmbH & Co. KG Gewerbepark 9 D 92278 Illschwang Germany

8.1 Installation and Handover Log

Site:

Company:

Street:

Town:

Country:

Device / system:

Manufacturer:

Type / model:

Serial no.:

Year of
construction:

Responsible retailer:

The above product has been assembled, checked for function and safety and put into operation. Installation was carried out by:

the operator

the technical expert

The operator confirms that the product type has been set up correctly, that he/she has read and understood all information contained in these operating instructions and the log, and that he/she keeps this documentation accessible to the instructed operator at all times.

The operator confirms that after installation and commissioning by a person trained by the manufacturer or an authorised dealer (expert), instruction in the function, handling, safety-relevant specifications, maintenance and care of the machine has taken place, documents, information and specifications of the machine have been provided and the product is working properly.

IMPORTANT NOTES:

IF THE ABOVEMENTIONED POINTS ARE NOT FULFILLED, THE WARRANTY CLAIM IS EXCLUDED:

The warranty is only valid in conjunction with compliance and evidence of proper assembly, handover, and if necessary training, as well as yearly maintenance carried out by an expert authorised by the manufacturer. The interval between services must not exceed 12 months. In case of non-standard use or multi-shift or seasonal use, a bi-annual inspection and maintenance must be arranged.

Warranty claims are only recognised if all points in the log and operating instructions have been met, the claim is asserted immediately after detection and **this log is sent to the manufacturer along with the maintenance and service logs.**

Further specific information about the warranty, such as scope, requirements and specifications, are described in the operating instructions and must be observed.

Damages and complaints caused by improper handling; failure to maintain and service; use of unsuitable or unspecified assembly, operating, maintenance or service products; mechanical damage; intervening in the unit without consultation or by an unauthorised expert are excluded from the warranty. For systems that have not been installed by an authorised expert, the warranty is limited by agreement of the manufacturer to the provision of the necessary spare parts.

Expert name and company stamp
if necessary, number and name of retailer

Date and expert signature

Operator name and company stamp

Date and operator signature

8.2 Inspection Plan

Inspection	1	2	3	4	5	6
Date						
Nameplate						
Quick reference guide						
Operating instructions						
Safety label						
Operation label						
Other labels						
Construction (deformation, cracks)						
Fixing dowels and stability						
Condition of concrete floor (cracks)						
Condition / general condition						
Condition / cleanliness						
Condition / care and sealing						
Condition / liquids						
Condition / lubrication						
Condition / aggregate						
Condition / drive						
Condition / motor						
Condition / transmission						
Condition / cylinder						
Condition / valve						
Condition / electrical control						
Condition / electric buttons						
Condition / electric switches						
Condition / electric lines						
Condition / hydraulic lines						
Condition / hydraulic screws						
Condition / pneumatic lines						
Condition / pneumatic screws						
Condition / tightness						
Condition / bolts and bearings						
Condition / consumables						
Condition / covers						
Condition / functions under load						
Condition / safety-relevant components						
Condition / electrical safety device						
Condition / hydraulic safety device						
Condition / pneumatic safety device						
Condition / mechanical safety device						
Condition / functions under load						
Inspection sticker issued						

8.3 Visual inspection (authorised expert)

Inspection Certificate
relating to a regular / extraordinary inspection / audit *)

The device has undergone a readiness test.
No / the following *) defects were found:

Inspection contents: functional and visual inspection according to specifications
Pending partial inspection:

There were no *) concerns arising from commissioning, an audit is not *) required.

(Place, date)

(Technical expert signature)

Confirmation of acceptance:

(Name of technical expert)

(Title)

(Address)

(Employed at)

Operator (company stamp, date, signature)

Faults noted **) _____

Faults remedied **) _____

*) Delete if not applicable
**) Confirmation of operator or a representative with date and signature

Visual inspection (authorised expert)

Inspection Certificate

relating to a regular / extraordinary inspection / audit *)

The device has undergone a readiness test.
No / the following *) defects were found:

Inspection contents: functional and visual inspection according to specifications
Pending partial inspection:

There were no *) concerns arising from commissioning, an audit is not *) required.

(Place, date)

(Technical expert signature)

Confirmation of acceptance:

(Name of technical expert)

(Title)

(Address)

(Employed at)

Operator (company stamp, date, signature)

Faults noted **) _____

Faults remedied **) _____

*) Delete if not applicable

**) Confirmation of operator or a representative with date and signature

Visual inspection (authorised expert)

Inspection Certificate

relating to a regular / extraordinary inspection / audit *)

The device has undergone a readiness test.
No / the following *) defects were found:

Inspection contents: functional and visual inspection according to specifications
Pending partial inspection:

There were no *) concerns arising from commissioning, an audit is not *) required.

(Place, date)

(Technical expert signature)

Confirmation of acceptance:

(Name of technical expert)

(Title)

(Address)

(Employed at)

Operator (company stamp, date, signature)

Faults noted **) _____

Faults remedied **) _____

*) Delete if not applicable

**) Confirmation of operator or a representative with date and signature

Visual inspection (authorised expert)

Inspection Certificate

relating to a regular / extraordinary inspection / audit *)

The device has undergone a readiness test.
No / the following *) defects were found:

Inspection contents: functional and visual inspection according to specifications
Pending partial inspection:

There were no *) concerns arising from commissioning, an audit is not *) required.

(Place, date)

(Technical expert signature)

Confirmation of acceptance:

(Name of technical expert)

(Title)

(Address)

(Employed at)

Operator (company stamp, date, signature)

Faults noted **) _____

Faults remedied **) _____

*) Delete if not applicable

**) Confirmation of operator or a representative with date and signature

Visual inspection (authorised expert)

Inspection Certificate relating to a regular / extraordinary inspection / audit *)

The device has undergone a readiness test.
No / the following *) defects were found:

Inspection contents: functional and visual inspection according to specifications
Pending partial inspection:

There were no *) concerns arising from commissioning, an audit is not *) required.

(Place, date)

(Technical expert signature)

Confirmation of acceptance:

(Name of technical expert)

(Title)

(Address)

(Employed at)

Operator (company stamp, date, signature)

Faults noted **) _____

Faults remedied **) _____

*) Delete if not applicable

**) Confirmation of operator or a representative with date and signature

Visual inspection (authorised expert)

Inspection Certificate

relating to a regular / extraordinary inspection / audit *)

The device has undergone a readiness test.
No / the following *) defects were found:

Inspection contents: functional and visual inspection according to specifications
Pending partial inspection:

There were no *) concerns arising from commissioning, an audit is not *) required.

(Place, date)

(Technical expert signature)

Confirmation of acceptance:

(Name of technical expert)

(Title)

(Address)

(Employed at)

Operator (company stamp, date, signature)

Faults noted **) _____

Faults remedied **) _____

*) Delete if not applicable

**) Confirmation of operator or a representative with date and signature

