

Application

- Check-in
- Repair and maintenance
- Testing equipment

Approvals

- Renault
- Volkswagen Group



Biglift 2.65 F 550

Electro-hydraulic twin-ram lift, 6.5 t with platforms

Description:

Steel cassette:

- Waterproof steel cassette

Hydraulic unit:

- Hard-chrome plated cylinder
- Flexible synchronization and safety system
- Corrosion-free guiding elements
- Pump unit with immersed motor
- Ecological hydraulic fluid
- Pneumatic emergency lowering
- Programmable pushbutton control unit – great stability, even with uneven weight distribution; due to the cylinder diameter of 213 mm

Superstructure:

- A set of platforms with drive-on ramps and stops

Standard colours

- Platforms: Grey RAL 7016
- Ramps: Red RAL 3020

Technical data	
Lifting capacity	6,500 kg
Lifting height	1,865 mm
Working height	2,045 mm
Cylinder diameter	2 x 213 mm
Distance between cylinders	1,550 mm
Lifting / lowering time	app. 45 Sec.
Foundation depth	2,625 mm
Pump unit	3.0 kW
Ecological hydraulic fluid	18 l
Voltage	230/400 V - 50 Hz - 16 A

Platforms	
Total length	app. 6,800 mm
Usable length of platform	5,500
Wheel base	app. 5,000 mm
Platform width	650 mm
Distance between platforms	900 mm
Drive-on height	180 mm

Scissor jack (Option)	
Lifting capacity	2,600 Kg
Lifting height	250 mm
Operation	Air-hydraulic
Lift positions	Middle / 790 - 1.460 mm

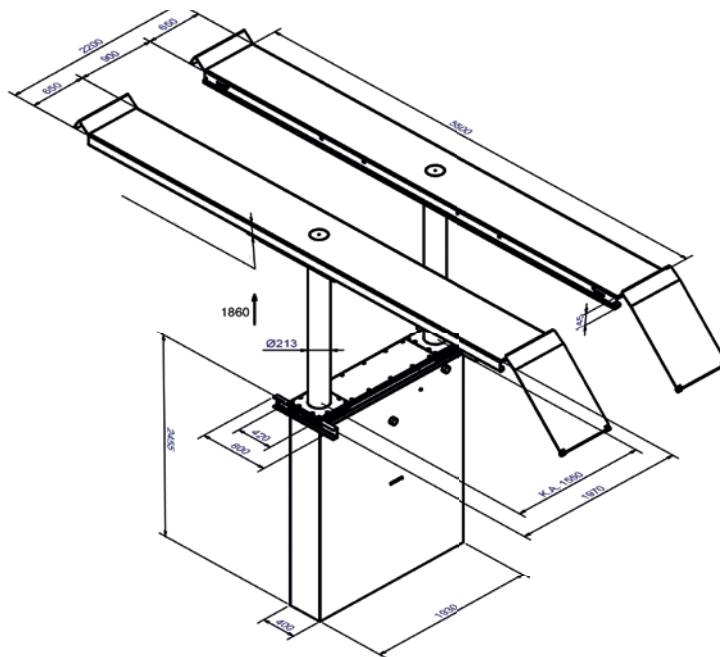

autop Maschinenbau GmbH

Sandkampstraße 90
 48432 Rheine | Germany
 ☎ +49 5971 8602-02
 ☎ +49 5971 8602-25
 ✉ info@autopstenhoj.com

STENHOJ A/S

Barrit Langgade 188-190
 7150 Barrit | Denmark
 ☎ +45 76821-330
 ☎ +45 76821-331
 ✉ info@autopstenhoj.com

Versions:

Steel cassette:

- Zinc-coated
- Coated

Installation:

- Superstructure on floor
- Superstructure in floor

Optional extras:

- LED-Lighting set
- Scissor jack

Special colours available
 on request!

