



Application

- Repair and maintenance

Approvals

- BMW
- Volkswagen Group
- Volvo

Magnat 35

Electro-hydraulic 2-post lift, 3.5 t capacity

Description:

Posts:

- Asymmetric post installation for ideal door-opening angle
- Very stable bent posts
- Without base frame
- One hydraulic unit
- Carriage with slide blocks
- Pushbutton control unit with alarm signal
- Adjustable top stop
- Mechanic synchronization
- Safety ratchet system

Arms:

- Double telescopic front and rear arms, as standard
- Possibility of parallel parking of arms
- Automatic arm locking system
- Low minimum height

Standard colours

- Arms: Red RAL 3020
- Posts: Grey RAL 7016

| Technical data | |
|-------------------------|----------------------------|
| Lifting capacity | 3,500 kg |
| Lifting height | 1,800 mm |
| Working height | 1,940 mm |
| Lifting / lowering time | 30 Sec. |
| Pump unit | 1x 2.2 kW |
| Voltage | 3x230/400 V-50/60Hz - 16 A |

| Arm superstructure | |
|---------------------------------------|--|
| Lifting pad included in the delivery | F: (95 - 140 mm) |
| Min. height | 95 mm |
| Drive-through width | BMW: 2,250 mm Uni: 2,450 mm |
| Width between posts | BMW: 2,560 mm Uni: 2,760 mm |
| Total width - outer edges base plates | BMW: 3,245 mm Uni: 3,495 mm |
| Total height inkl. portal | 4,009 mm + 250 mm |
| Arm length front, min. - max. | F BMW: 590 - 995 mm F Uni: 640 - 1,145 mm |
| Arm length rear, min. - max. | F BMW: 710 - 1,275 mm F Uni: 880 - 1,560 mm |

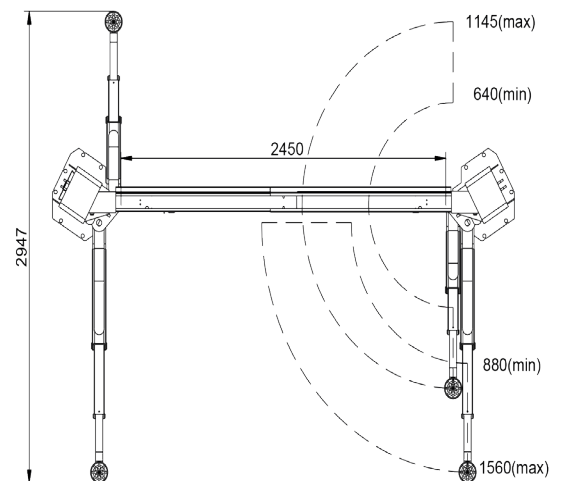
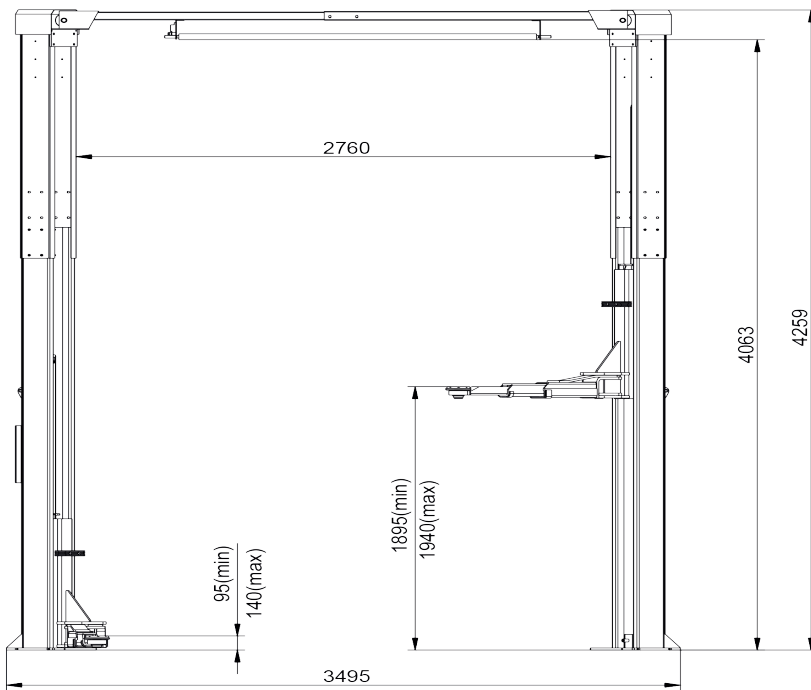

autop Maschinenbau GmbH
 Sandkampstraße 90
 48432 Rheine | Germany
 ☎ +49 5971 8602-02
 📠 +49 5971 8602-25
 ✉ info@autopstenhoj.com

STENHOJ A/S
 Barrit Langgade 188-190
 7150 Barrit | Denmark
 ☎ +45 76821-330
 📠 +45 76821-331
 ✉ info@autopstenhoj.com

Versions:

- Available with different Voltages
- BMW- and Universal armset available

Optional extras:

- Set of expansion bolts
- A large program of lifting pads

Special colours available on request!

