

### Application

- Check-in
- Repair and maintenance
- Testing equipment

### Approvals

- Volkswagen Group

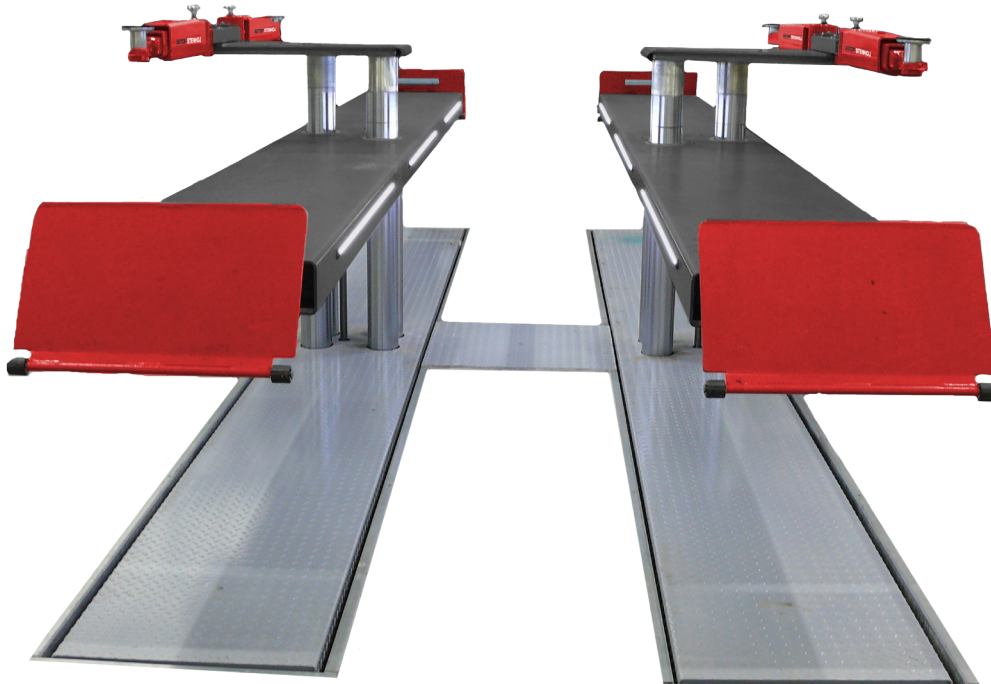

# Biglift 4.55 Combi

Electro-hydraulic 2xtwin-ram lift, 5.5 t with platforms and Free-wheel device with arms

## Description:

### Steel cassette:

- Waterproof steel cassette

### Hydraulic unit:

- Hard-chrome plated cylinder
- Flexible synchronization and safety system
- Corrosion-free guiding elements
- Pump unit with immersed motor
- Ecological hydraulic fluid
- Pneumatic emergency lowering
- Programmable pushbutton control unit – great stability, even with uneven weight distribution (all 4 cylinders in operation)

### Superstructure:

- A set of platforms with drive-on ramps and stops

### Free-wheel device Saav:

- Double telescopic arms, crosswise adjustable
- Internal arm locking system
- Low minimum height

### Standard colours

- Platforms: Grey RAL 7016
- Free-wheel device: Base plate: Grey RAL 7016, Arms and slider: Red RAL 3020
- Ramps: Red RAL 3020

Technical data	
Lifting capacity	5,500 kg
Lifting height	1,895 mm
Working height	P: 2,060 mm WF: 2.210 - 2.270 mm
Cylinder diameter	8 x 140 mm
Distance between cylinders	1,240 - 1,850 mm
Lifting / lowering time	app. 38 Sec.
Foundation depth	2,625 mm
Pump unit	3.0 kW
Ecological hydraulic fluid	18 l
Voltage	230/400 V - 50 Hz - 16 A

Arm superstructure	
Total width	3,265 mm
Lifting pad included in the delivery	11028 (135 - 195 mm)
Min. height	135 - 195 mm
Arm length, min. - max.	715 - 1,410 mm

Platforms	
Total length	app. 6,800 mm
Usable length of platform	5,500 mm
Wheel base	app. 5,000 mm
Platform width	650 mm
Distance between platforms	900 mm
Drive-on height	165 mm

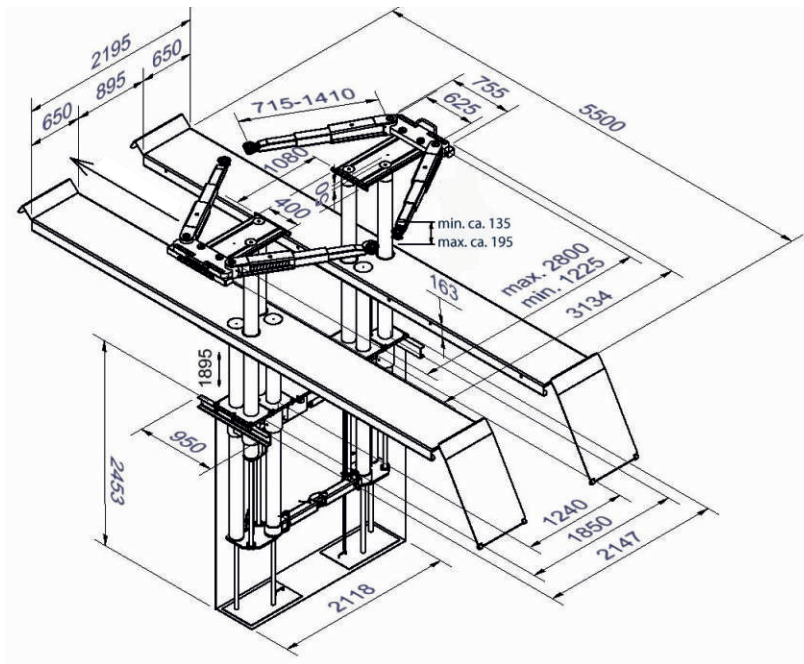

**autop Maschinenbau GmbH**  
 Sandkampstraße 90  
 48432 Rheine | Germany  
 ☎ +49 5971 8602-02  
 📠 +49 5971 8602-25  
 ✉ info@autopstenhoj.com

**STENHOJ A/S**  
 Barrit Langgade 188-190  
 7150 Barrit | Denmark  
 ☎ +45 76821-330  
 📠 +45 76821-331  
 ✉ info@autopstenhoj.com

### Versions:

#### Steel cassette:

- Zinc-coated
- Coated

#### Installation:

- Superstructure on floor
- Superstructure in floor with or without flush floor device

### Optional extras:

- LED-Lighting set
- Large program of extra pads

**Special colours available on request!**

