

Triolift 3.35 Fn 420

Electro-hydraulic 3-level work bay, 3.5 t, with platforms and scissor free-wheel lift

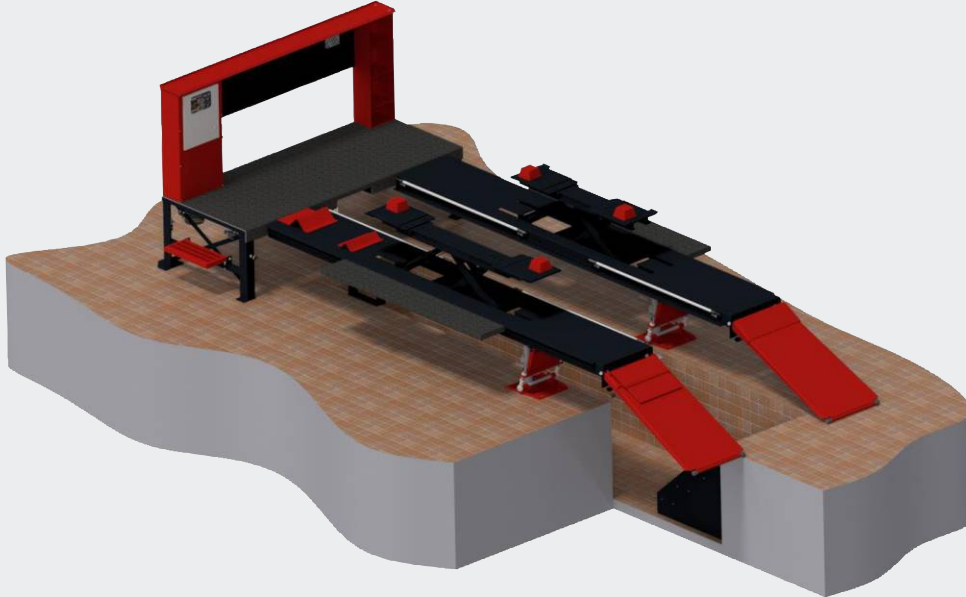

Application

- Check-in
- Repair and maintenance

Approvals / recommendations

- Opel

Description:

- Work on 3 levels: underbody, wheels and brakes, motor
- The perfect team bay for quick execution at high efficiency and little space requirement!

Pit:

- 1 entrance / exit stair with 4 steps at rear end

Hydraulic unit:

- 2 hard-chrome plated hydraulic cylinders for raising of platforms, running smoothly in end position
- Levelling device and pneumatic safety ratchet
- Safety system through rigid fixation at the podium
- Electronic monitoring of synchronization
- Hydraulic pump unit with immersed motor
- Ecological hydraulic fluid
- Pneumatic emergency lowering
- Air preparation unit for oiled and regulated compressed air (min. 6 bar / max. 10 bar)

Platforms:

- A set of platforms with drive-on ramps and integrated steps in rear left and drive-over stops in front left position
- Lengthwise movable platform enlargement as step tread or as additional tool tray
- Bracket for impact wrench and holder for rubber blocs
- LED-lighting set with adjustable light angle
- As standard skid-proof surfaces

Scissor free-wheel lif:

- Electro-hydraulic with safety ratchet, integrated into platforms for low drive-over height
- Electronic monitoring of synchronization
- Delivery inclusive of 1 set of 4, H = 80 mm rubber blocks

Podium:

- Integrated control post with programmable pushbutton control unit and alarm signal / CE-stop
- Board with many holes for easy fixation of mirrors and other accessories or tools
- Integrated tool tray system
- Traffic mirror for monitoring of drive-in situation and for checking functionality of headlamps
- Steps on both sides left and right
- 1 compressed air connection on each side, front left and front right podium leg
- Expansion bolts incl.

Standard colours:

- Platforms: RAL 7016 - grey
- Ramps, podium: RAL 3020 - red



Scan the QR-Code for detailed product information.

Further Information on www.autopstenhoj.com

autop Maschinenbau GmbH

Sandkampstraße 90
48432 Rheine | Germany
☎ +49 5971 8602-02
☎ +49 5971 8602-25
✉ info@autopstenhoj.com

STENHØJ A/S

Barrit Langgade 188-190
DK-7150 Barrit
☎ +45 76 82 13 30
☎ +45 76 82 13 31
✉ info@autopstenhoj.com

Technical data	
Lifting capacity	3,500 kg
Stroke length	500 mm
Working height	650 mm (F) + 900 mm (Pit)
Lifting / lowering time	approx. 5 sec.
Foundation depth	1,340 mm (Pit)
Pump unit	3 kW
Hydraulic oil	10 l
Voltage	230/400 V / 50 Hz / 16 A

Pit	
Length	4,980 mm
Width	990 mm
Depth	900 mm

Platforms	
Total length	approx. 6,600 mm
Usable length of platform	4,200 mm
Wheel base	max. approx. 3,700 mm
Platform width	570 mm
Distance between platforms	905 mm
Drive-on height	approx. 150 mm

Free-Wheel lift	
Lifting capacity	3,500 kg
Length	1,450 - 2,060 mm
Lifting height	379 mm + rubber blocks
Drive-over height	30 mm
Lifting / lowering time	approx. 8 sec.
Operation	electro-hydraulic

Optional extras:

- Wheel retaining device for inner sides of platforms
- 24 l oil funnel
- 1,700 mm drive-on ramps
- Traverse for lifting 4 x 4 vehicles

Special versions and colours on request

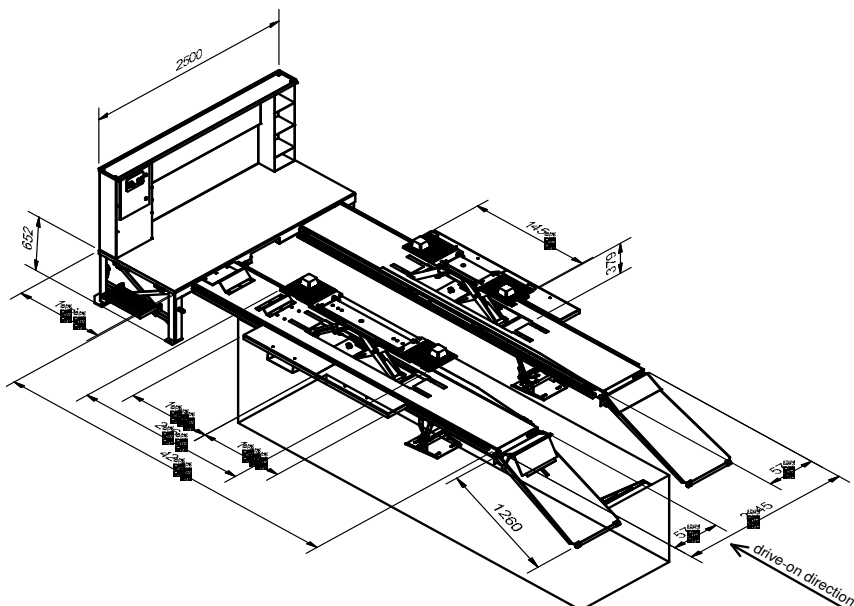

LED lighting set with adjustable light angle - Wheel retaining device



24 l oil funnel