

Application

- Repair and maintenance
- Body work

Approvals

- Saaa 145:
 - Volkswagen Group
- Saaa 230:
 - Renault
 - Volkswagen Group
- Saaa 265:
 - Mercedes-Benz
 - Volkswagen Group

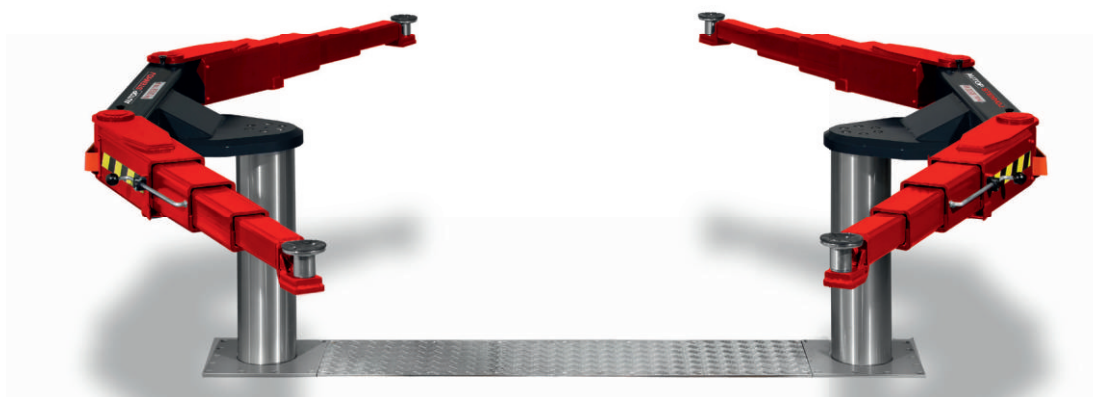

Biglift 2.65 Saaa

Electro-hydraulic twin-ram lift, 6.5 t with superstructure with arms

Description:

Steel cassette:

- Waterproof steel cassette

Hydraulic unit:

- Hard-chrome plated cylinder
- Flexible synchronization and safety system
- Corrosion-free guiding elements
- Pump unit with immersed motor
- Ecological hydraulic fluid
- Pneumatic emergency lowering
- Programmable pushbutton control unit – great stability, even with uneven weight distribution; due to the cylinder diameter of 213 mm

Superstructure:

- Triple telescopic arms
- Internal arm locking system
- Low minimum height

Saaa 265:

- Mechanical ratchet system integrated in the hydraulic unit
- Air preparation unit for oiled and regulated compressed air (min . 6 bar / max . 10 bar)

Standard colours

- Base plate: Grey RAL 7016
- Arms: Red RAL 3020

Technical data	
Lifting capacity	6,500 kg
Lifting height	1,865 mm
Working height	2,015 - 2,075 mm
Cylinder diameter	2 x 213 mm
Distance between cylinders	Saaa 145: 1,350 mm Saaa 230: 2,150 mm Saaa 265: 2,650 mm
Lifting / lowering time	app. 45 Sec.
Foundation depth	2,625 mm
Pump unit	3.0 kW
Ecological hydraulic fluid	18 l
Voltage	230/400 V - 50 Hz - 16 A

Arm superstructure	
Total width	3,390 mm
Lifting pad included in the delivery	11028 (135 - 195 mm)
Min. height	135 - 195 mm
Drive-through width	Saaa 230: 1,930 mm Saaa 265: 2,430 mm
Arm length, min. - max.	770 - 1,640 mm

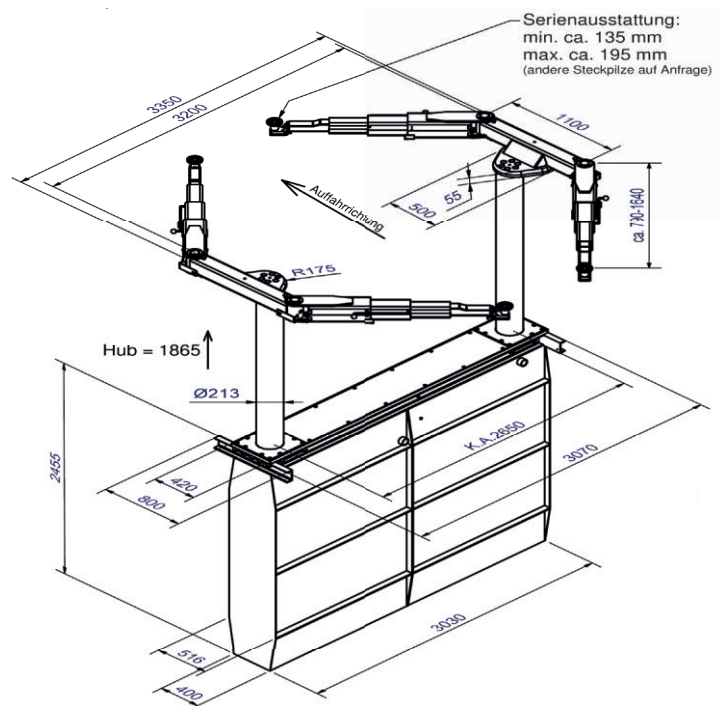
autop Maschinenbau GmbH

Sandkampstraße 90
 48432 Rheine | Germany
 ☎ +49 5971 8602-02
 📠 +49 5971 8602-25
 ✉ info@autopstenhoj.com

STENHOJ A/S

Barrit Langgade 188-190
 7150 Barrit | Denmark
 ☎ +45 76821-330
 📠 +45 76821-331
 ✉ info@autopstenhoj.com

Versions:

- Saaa 145, Saaa 230, Saaa 265

Steel cassette:

- Zinc-coated
- Coated
- Self-carrying (Saaa 230)

Installation:

- Superstructure on floor
- Superstructure in floor with covers (Saaa 230)
- Ceiling installation (Saaa 230)

Optional extras:

- Large program of extra pads

**Special colours available
 on request!**

