

USER'S MANUAL

Evolution



GLOBALJIG
International S.r.l.

Via Aurelia Ovest, Km. 383 - 54100 Massa (MS) - ITALY - Tel.: +39 0585 8364 - Fax: +39 0585 833880 - www.globaljig.it
Società unipersonale sotto la direzione e controllo della Bellini Srl. - Capitale sociale € 100.000,00 i.v.
Iscritta al Reg. Imprese di Massa Carrara al N° 01064230459

USER'S MANUAL

Evolution

Year of Manufacture.....

CONTENTS

1.	USE AND STORAGE OF THE USER'S MANUAL	3
1.1.	<i>Purpose and object of the User's Manual</i>	3
1.2.	<i>Definitions and terminology</i>	4
1.3.	<i>Arrangement of the manual</i>	5
1.4.	<i>Storing the manual</i>	5
1.5.	<i>Updates</i>	5
2.	GENERAL DESCRIPTION	6
2.1.	<i>Lift bench dimensions: Work area</i>	6
2.2.	<i>User</i>	6
2.3.	<i>Supply</i>	6
2.4.	<i>Identification of the various versions</i>	7
2.5.	<i>Lift bench use potential and limitations</i>	7
2.6.	<i>Vehicle types that can be lifted</i>	8
2.7.	<i>Mode of operation</i>	8
2.8.	<i>Safety</i>	8
2.9.	<i>Operating instructions</i>	9
3.	TECHNICAL DESCRIPTION	9
3.1.	<i>General information</i>	9
3.2.	<i>Parts</i>	9
3.3.	<i>Technical description</i>	14
3.4.	<i>Electrical, pneumatic and hydraulic system diagrams</i>	14
4.	INSTALLATION	15
4.1.	<i>Transport and handling</i>	15
4.2.	<i>Storage</i>	15
4.3.	<i>Installing the lift bench</i>	15
4.4.	<i>Operating environment</i>	16
4.5.	<i>Installation characteristics</i>	16
4.6.	<i>System connections</i>	17
4.7.	<i>Starting up the lift bench</i>	17
4.8.	<i>Installing the pulling arm</i>	18

5.	OPERATING INSTRUCTIONS.....	23
5.1.	<i>Introductory note</i>	23
5.2.	<i>Controls</i>	23
5.3.	<i>Operating procedures</i>	25
5.4.	<i>Adjustments</i>	26
6.	SAFETY.....	27
6.1.	<i>Introduction.....</i>	27
6.2.	<i>Guards</i>	27
6.3.	<i>Residual risks</i>	28
7.	MAINTENANCE	29
7.1.	<i>Introductory note</i>	29
7.2.	<i>Customer services.....</i>	29
7.3.	<i>Scheduled maintenance</i>	30
	7.3.1. <i>Cleaning</i>	30
	7.3.2. <i>Checking safety lock status.....</i>	30
7.4.	<i>Special maintenance</i>	30
8.	SPARE PARTS	31
8.1.	<i>General information.....</i>	31
8.2.	<i>Recommendations on the spare parts to be kept on hand.....</i>	31
9.	INSTRUCTIONS FOR DISMANTLING AND DISPOSING OF THE LIFT BENCH.....	32
9.1.	<i>Removing lift bench connections</i>	32
9.2.	<i>Arranging the lift bench for handling.....</i>	32
9.3.	<i>Disposing of the lift bench</i>	32
10.	ATTACHMENTS	33
10.1.	<i>Attachment 01 - Lift bench dimensions</i>	34
10.2.	<i>Attachment 02 - Lift bench work area.....</i>	35
10.3.	<i>Attachment 03 - Wiring diagram</i>	36
10.4.	<i>Attachment 04 - Hydraulic system diagram</i>	37
10.5.	<i>Attachment 05 - Pneumatic system diagram</i>	38
10.6.	<i>Attachment 06 - Blow-up of pulling arm</i>	39
10.7.	<i>Attachment 07 - Blow-up of control unit</i>	40
10.8.	<i>Attachment 08 – Figures.....</i>	41
11.	MACHINE LOG BOOK	42

1 USE AND STORAGE OF THE USER'S MANUAL

N.B.: The term **LB (ABBREVIATION OF LIFT BENCH)** in the present manual is used to indicate the EVOLUTION motor vehicle Lift Bench.

1.1 Purpose and object of the User's Manual

The User's Manual provides the indications necessary to use the EVOLUTION motor vehicle LB properly. It describes the physical and functional characteristics of this lift bench.

The manual must accompany the LB throughout its entire life cycle. If the unit is turned over to a third party, the manual must also be passed on to ensure operator and user safety.

The manual enables you to perform the following operations:

- INSTALLATION
- OPERATION
- MAINTENANCE
- DISPOSAL

It has been written for both the user and the operator charged with performing the above-mentioned activities. It indicates (where necessary) the qualifications required for these persons with reference to paragraph 1.2.

Noncompliance with the prescriptions outlined in this manual relieves GLOBALJIG INTERNATIONAL of any responsibility for any results pursuant to such negligence.

It must also be underlined that GLOBALJIG INTERNATIONAL cannot be held responsible for the risks introduced by:

- improper use of the LB;
- use contrary to specific national standards;
- installation that does not comply with what is laid out in the present manual;
- inadequate maintenance;
- unauthorized modifications or intervention;
- use of parts other than original, specific spare parts;
- noncompliance with the instructions in this manual.

The manual cannot constitute a reference if modifications are to be made which alter the LB configuration. In this case, the manufacturer shall only be held responsible for manufacturing defects.

1.2 Definitions and terminology

- User
- Operator
- EVOLUTION LB Lift bench
- The term "User" is used to indicate the qualified person assigned to ongoing use of the LB.

- The "Operator" is the person(s) charged with installing, starting up, regulating, performing maintenance, cleaning and repairing the LB.

When reading this manual, the term "Manual" used in regard to the EVOLUTION unit is understood as indicating this User's Manual.

The operations mentioned in paragraph 1.1 must be performed by personnel qualified for the specific activity. The qualification level indicates what activities the operator is qualified to perform according to the manufacturer's indications.

Qualification 1

Personnel with this level of qualification do not have specific training in the area but can run simple operations related to use of the LB. Persons with this level of qualification can install, regulate the unit and perform ordinary and special maintenance.

Qualification 2

Personnel with this level of qualification have special training in electrical operations. Persons with this level of qualification can install, regulate the unit and perform ordinary and special maintenance. Instruction on the above activities is received through training with GLOBALJIG Technicians and through a thorough reading of this manual.

Qualification 3

Personnel with this level of qualification have special training in Automatic Machinery with installed electronics and can perform electrical operations. Persons with this level of qualification can install, regulate the unit and perform ordinary and special maintenance. Instruction on the above activities is received through training with GLOBALJIG Technicians and through a thorough reading of this manual. Persons with this qualification must be prepared to use the commands on the EVOLUTION control panel; such preparation is obtained by thoroughly reading this User's Manual. The manual contains notes that call the user/operator's attention to specific procedures or to particular operations.

There are three types of notes:

- NOTE:** These are warnings to guide the operator and improve operations, or to better indicate particular characteristics of the lift bench.
- ATTENTION:** These are very important warnings that specify what to do or not to do, or which indicate particular precautions to be taken before operating the LB.
- DANGER:** These are very important warnings that specify what to do or not to do, or which indicate particular precautions to be taken before using the LB in order to prevent injuries.

1.3 Arrangement of the Manual

The present Manual has been conceived in line with the indications in the Machine Directive (89/392) and the regulations included therein. The manual is organized with:

- Label ID page (correlation with the specific lift).
- Contents.
- Attached documentation.

1.4 Storing the Manual

The LB User's Manual must be available to the user at all times. It must, therefore, be kept in a specially arranged place in the immediate vicinity of the unit so that it can be promptly consulted, ensuring that all LB activities are performed correctly.

The User's Manual must be kept away from sources of heat, moisture or other environmental conditions that could damage it. The User's Manual must be complete to ensure precise knowledge of the characteristics of the LB. Therefore, check that all parts listed in the table of contents are present.

If the manual is lost or irreparably damaged, contact GLOBALJIG INTERNATIONAL for a replacement copy.

1.5 Updates

Publication of an updated version of the User's Manual does not obligate the manufacturer to update the present manual except in those cases where devices have been introduced to limit the hazards during LB operations.

2 GENERAL DESCRIPTION

2.1 Lift bench dimensions: Work area

The dimensions of the LB are given in the figure below.

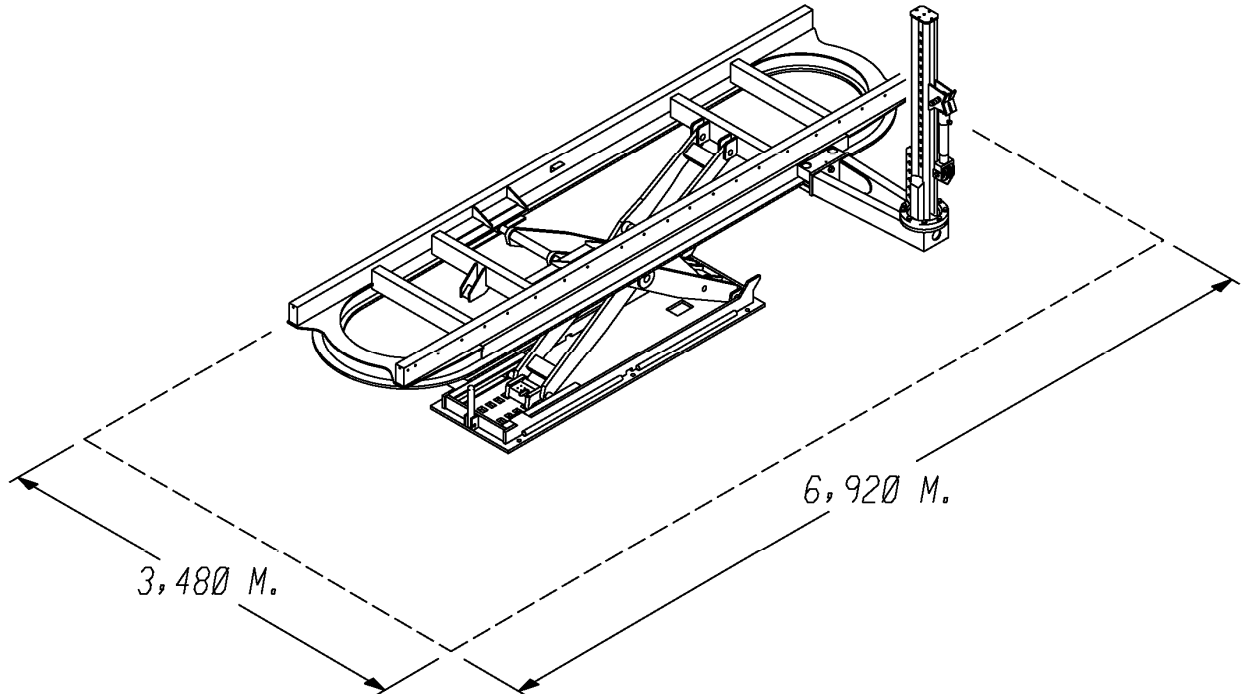

2.2 User

The LB is simple to use and does not require any additional training above what is outlined in chapter 1, paragraph 1.2. A thorough reading of this manual is deemed enough to guarantee adequate preparation for correct operation of the LB. In particular, attention must be paid to the aspects regarding HUMAN and Environmental safety. The operations involved in regulating or maintaining the unit must be performed by previously qualified personnel as outlined in chapter 1, paragraph 1.2.

2.3 Standard Supply (G621/2)

Below is a list of the parts that make up the LB and which are supplied to the Customer:

- Lift bench
- Control panel including mobile push-button strip.
- Complete pulling arm.
- Ramps.
- Winch.

2.4 Identification of the various versions

There are several versions of the LB and they can even differ in the type of power supply used. The various versions are:

- 220/400 V - 50/60 Hz three-phase
- 200V - 50/60 Hz three-phase

2.5 Lift bench use potential and limitations

- Capacity max: 3500 kg.
- Oil tank: 6 l.
- Hydraulic pressure max. 330 bar.
- Electrical power supply: depending on the version (see par. 2.4)
- Rated power: 1.5 kW.
- Pneumatic feed: 6 = 8 bar.
- Lift time: 55 sec.
- Lowering time: 50 sec.
- Max upward stroke: 1450 mm.
- Average sound level: < 70 dB (A).

Lift dimensions:

- Length 4620 mm.
- *Max length with pulling arm 6920 mm.
- Width 1180 mm.
- *Max width with pulling arm 3480 mm.
- Min LB height 370 mm.
- Max LB height 1350 mm.
- Max height with pulling arm 1800 mm.

Control unit dimensions:

- Length 340 mm.
- Width 320 mm.
- Height: 850 mm.

Weight

- Bench + Lift 1580 Kg.
- Control unit weight: 45 Kg.
- Complete pulling arm: 286 Kg.
- Ramps..... 84 Kg.
- Winch..... 43 Kg.

* see par. 2.1 Lift bench dimensions: Work area

2.6 Vehicle types that can be lifted

The unit can lift all vehicles present on the market as long as the distance between tires complies with what is reported below:

- Tread: 1250 - 1750 mm.
- Wheel base: 4200 mm.

2.7 Mode of operation

The LB has been designed for manual operation. It, therefore, requires the operator to perform only simple operations controlling upward, downward movement and stopping the unit. These operations are performed with the push-button control panel.

No functions are, or can be, foreseen that would reduce operator safety while operating the LB.

2.8 Safety

The LB has been designed and manufactured in compliance with the applicable European Directives and the pertinent reference standards. The personnel using the unit must always perform activities as indicated, making certain that they are properly qualified.

If a situation arises which was not foreseen in the manual, contact GLOBALJIG Technical Services before proceeding. If not, GLOBALJIG shall decline any responsibility derived from unpredictable, improper use. The topics covering safety devices and safety arrangements are handled in-depth in chapter 6.

!!! DANGER !!!

GLOBALJIG recommends that the individual activities be performed by a single person as this will prevent any reciprocal exposure to risks.

2.9 Operating indications

The electric-hydraulic control unit has a plate, illustrated below, summarizing the most important operating instructions and indicating what the operator must do while running the LB.

OPERATING INSTRUCTIONS

- Before using the lift, read the user's manual carefully and check it frequently.
- The lift can only be used by specially trained, authorized personnel.
- Never use the lift for purposes other than those outlined in the user's manual.
- Never allow anyone to climb onto the load or lift structure no matter what condition it is in.
- Make certain that the weight of the vehicle to be lifted and the distribution of the load comply with the indications in the user's manual.
- Never exceed the maximum rated capacity for the lift.
- Make certain that the vehicle is stable on the support elements before and during lifting operations.
- Make certain that no conditions arise which could be hazardous to persons or things while the lift is being raised or lowered.
- When lowering, make certain that there is nothing in the operating area which could prevent lift movement.
- When running the unit, NEVER let anyone remain in the lift operating area.
- In case of breakdown, press the emergency ("mushroom-shaped") button on the remote control.
- Before performing any maintenance on the lift, set the main switch on the control panel to 0 (door lock).
- Operations on the lift systems must only be performed by professionally qualified personnel.
- Tampering with the safety devices violates European safety standards.

A41453/1.1

3 TECHNICAL DESCRIPTION

3.1 General information

The LB has been designed, created and built considering the operating needs of the body shop working on motor vehicle sheet metal.

3.2 Identification of the parts

The location of the main parts of the LB are identified in the figure below:

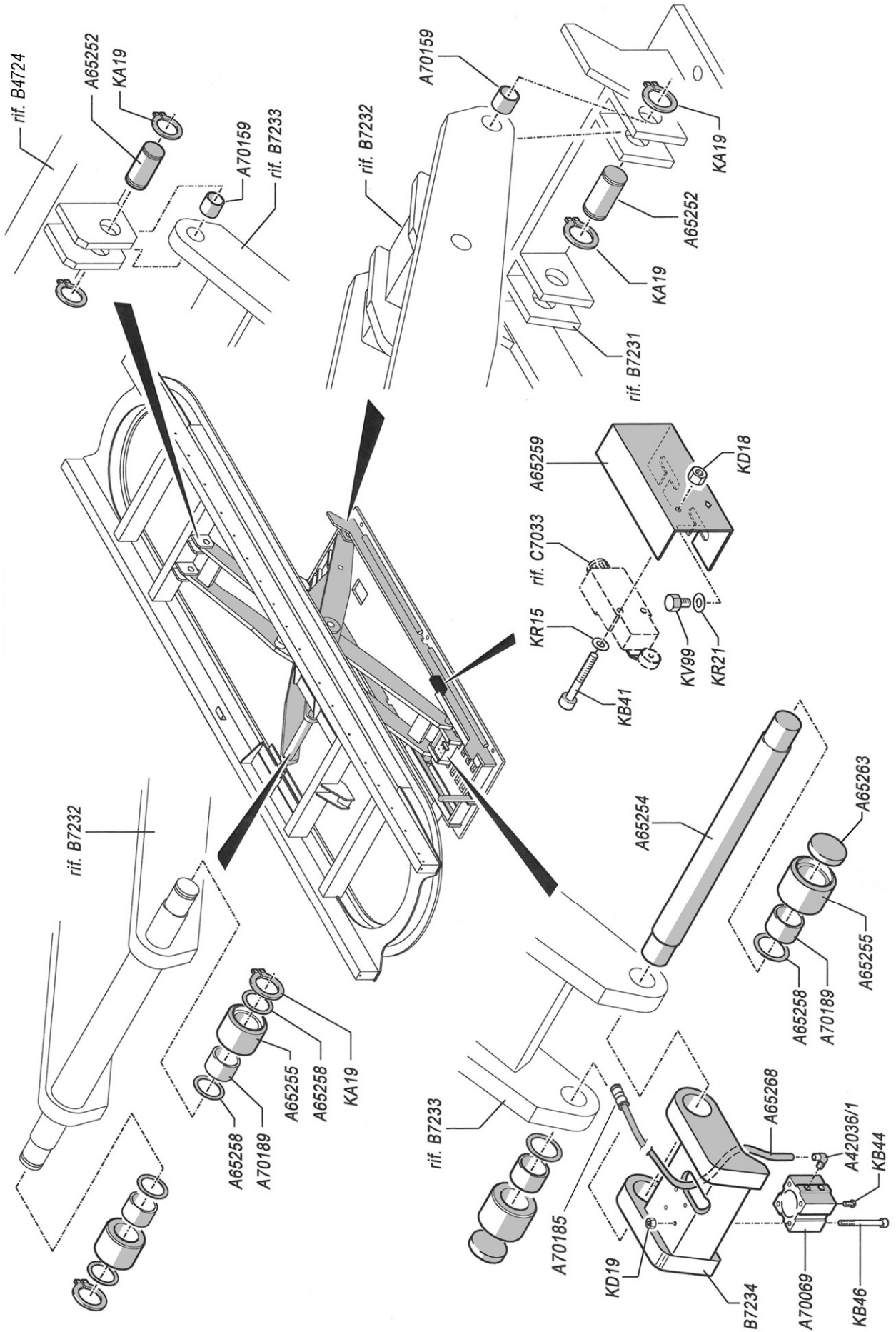

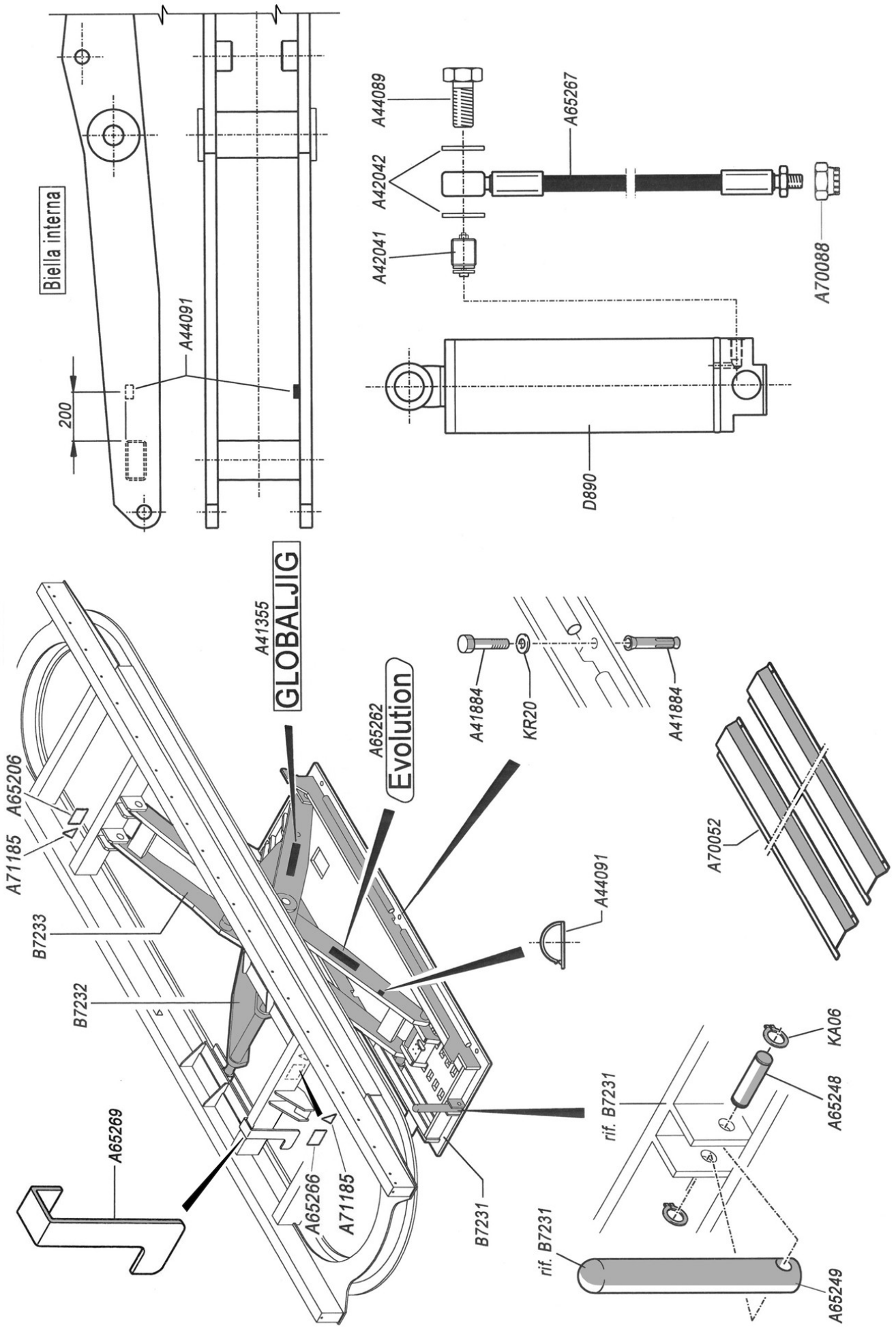

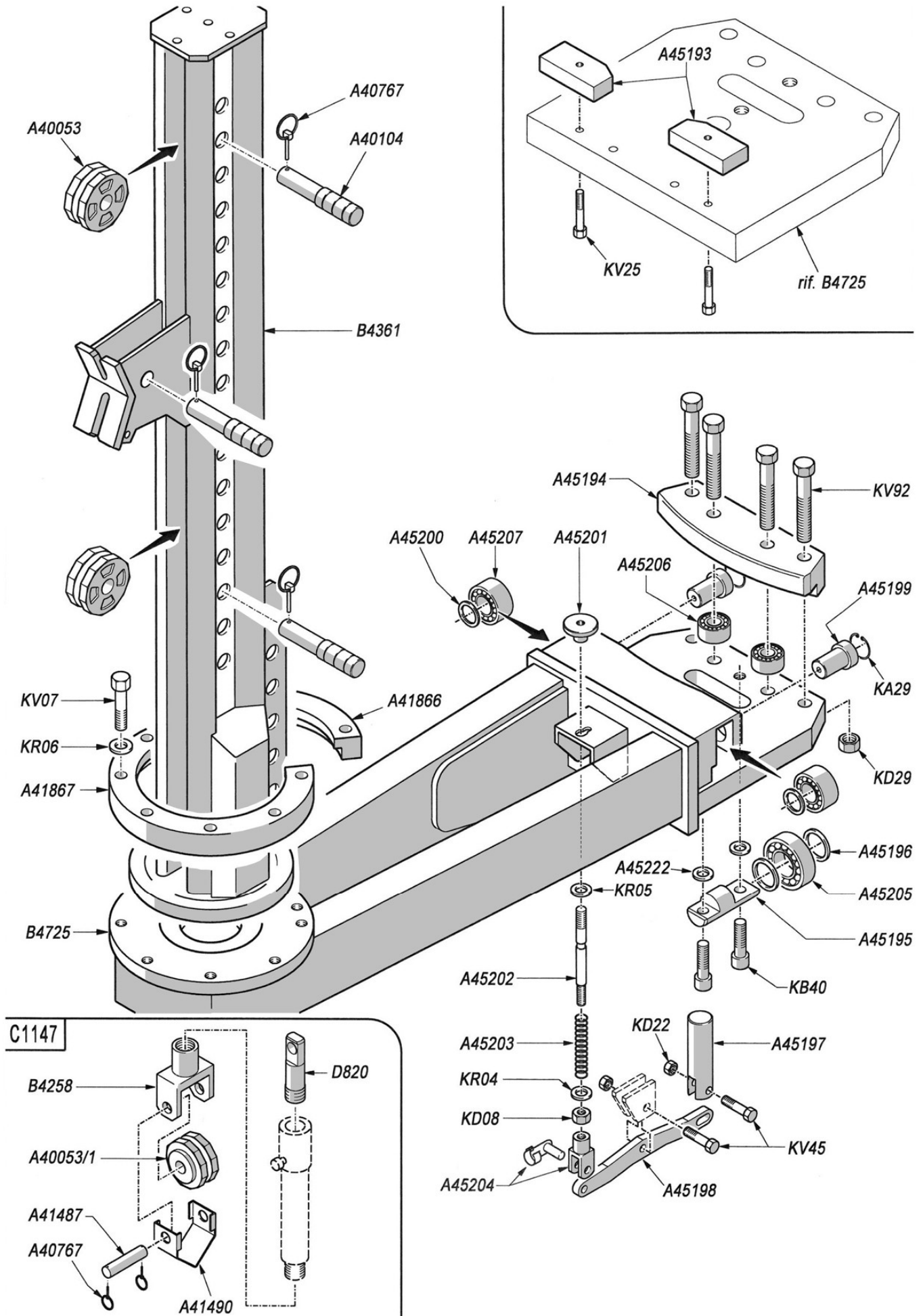

3.3 Technical description

EVOLUTION is an LB designed and built to lift motor vehicles so that body repairs can be made.

Its structure permits rapid lifting of the vehicle and proves ideal for use side-by-side with the more complete units: benches with jig.

Physically, the LB is composed of a lower structure, that is the base to be secured to the ground, an upper frame and two lifting rods that cross each other like a scissors and connect the upper and lower frames. Lifting is achieved by two hydraulic cylinders controlled by a special electro-hydraulic control unit set in a structure that includes the electrical panel and pneumatic solenoid valve.

The hydraulic control unit is made up of a motor that runs a hydraulic pump. The oil is held in a special tank. The control unit also has a safety release solenoid valve.

The safety pawl is always active and, in the event of hydraulic system failure, it cuts in, preventing the lift from dropping.

This safety pawl is set flush in the special stops while parking to work at various heights. The user has a two-position button available. The first click controls descent only. If you continue pressing (to the second click) the safety pawl is disengaged. When the button is released, the safety device is automatically rearmed.

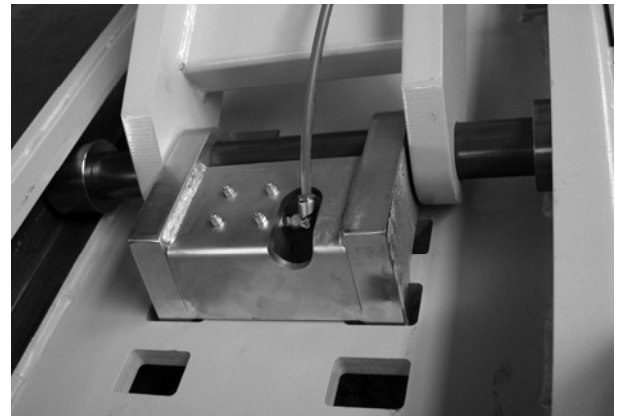
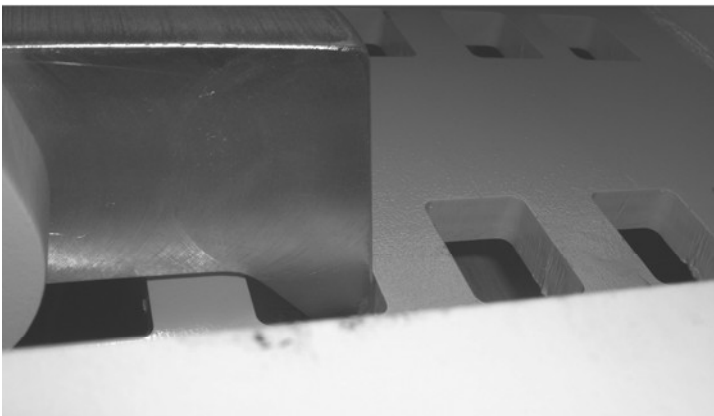

Upward movement of the lift arms is limited by an electric limit switch that cuts off the hydraulic control unit when the bench nears maximum height.

The upper frame is made up of rectangular steel profiles that are suitably shaped to facilitate installation of the various accessories.

Installation operations must be performed following the indications given in chapter 4 of this manual. The operating procedures are given in chapter 5.

3.4 Electrical, pneumatic and hydraulic system diagrams

The LB has electric, pneumatic and hydraulic systems. The diagrams for these systems are given in a special section of this Manual.

4 INSTALLATION

4.1 *Transport and handling*

The packaging used for shipping and handling the LB is made up of:

- 1 wooden pallet containing the LB.
Gross weight: approx. 1580 kg
- 1 crate containing the electric-hydraulic control unit.
Gross weight: approx. 45 kg
- 1 crate containing the pulling arm and standard accessories.
Gross weight: approx. 286 kg

A forklift rated for at least 2000 kg is required to move the complete package. The forks must be a minimum of 1.5 m long.

The same holds for moving the LB on the ground after it has been unpacked since there are no special accessories arranged for moving it. The hydraulic control unit is lifted using a forklift.

!! WARNING !!

*When lifting and handling the LB,
be particularly careful to prevent bumping, shaking and
jerking as this could throw the lift out of balance.*

4.2 *Storage*

The LB has been designed to be stored in environments having the following characteristics:

- temperature ranging between -25°C e + 55°C for long periods and between -25°C and 70°C for periods of less than 24 hours;
- relative humidity ranging between 30% and 95% (without any condensation).

The unit cannot be stored in places with characteristics different from those indicated above.

4.3 *Installing the lift bench*

- Establish the LB working position considering that the hose connecting the electro-hydraulic control unit to the LB is approximately 3.5 meters long and connects on the front opposite the vehicle ramp.
- Define the LB working area marking off a space of not less than 6.92 x 3.48 mt.

Make connections:

- Oil supply hose (unscrew the male / female caps)
- Air hose
- Limit switch cable
- Hook up the power supply (230/400 V – 50/60 Hz three-phase; or 200 V – 50/60 Hz three-phase) to the control unit using the special plug.

4.4 Operating environment

The LB has been designed to work indoors. For this reason the reference environmental parameters are:

- temperature range between +5°C and 40°C
- relative humidity between 30% and 95% (without any condensation)

In addition, the place where the LB is to be operated must have the following characteristics:

- The ceiling of the area must be high enough so that any vehicle can be lifted all the way without causing any damage. Check this height with particular vehicles.
- The support flooring must be smooth and level (free of any slope and/or rough spots).
If the flooring is not suitable, it can prove dangerous to use the LB and move it on the floor while loaded.
- The LB cannot be used in environments with characteristics that differ from the above.

4.5 Installation characteristics

The LB must be installed on a perfectly horizontal floor free of any bumps. The LB must be suitably secured to the floor with the 6 screw anchors supplied with the unit.

Operating the LB requires outside electrical and pneumatic power supplies with the following characteristics:

- electrical power supply from an industrial outlet, the voltage requirement depends on the particular model:
- * 240/415 V three-phase + ground and 50 Hz \pm 2% frequency, rated for a maximum 1.1 kW power absorption; the ground cable must have a minimum section of 2.5 mm²;
- * 200/230 V three-phase + ground and 50/60 \pm 2% frequency, rated for a maximum 1.1 kW power absorption; the ground cable must have a minimum section of 2.5 mm²;

!!! DANGER !!!

The Customer must install a differential, three-pole safety switch with a leak sensitivity of 30 mA upstream of the LB (in the building power supply panel) to ensure that the power supply is automatically cut off in case of LB insulation failure.

4.6 System connections

HYDRAULIC SYSTEM:

- Remove the plugs (male/female) from the hose fittings using 2 wrenches connected to one another (photos 1, 2 and 3).

PNEUMATIC SYSTEM:

- Connect the hose with quicklock fitting (from the control unit) to pipe (on the lift).
- Connect the hose fit with coupling (with ¼" female quicklock fitting), to the air feed.

ELECTRIC SYSTEM (up limit switch):

- Connect the plug and outlet of the wires coming from the control unit and the lift.

!! WARNING !!

For safety purposes, if the unit is not connected, or is connected improperly, the lift function is locked out.

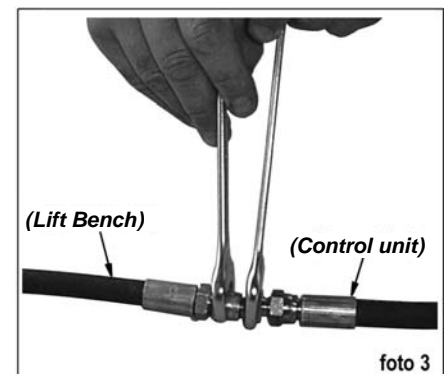
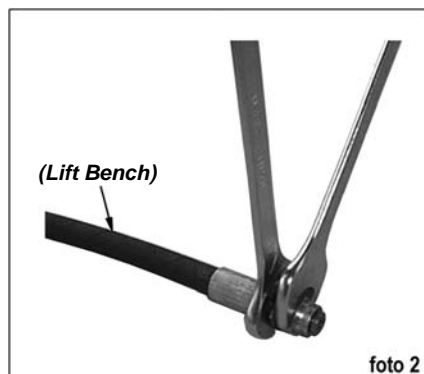
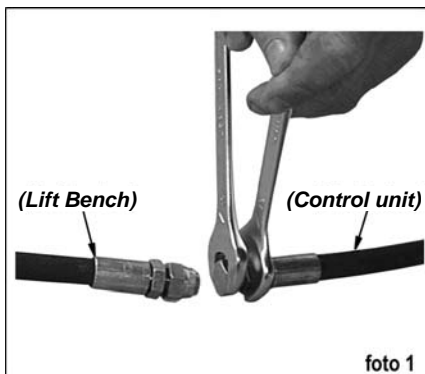

4.7 Starting up the lift bench

After having performed all hook-ups and connected all systems as indicated above, press the lift button on the remote control (fig. 5.1).

If the phase rotates in the right direction (RST), the LB rises.

If the LB does not move and the control unit motor is "running", do not insist further. It means that the motor is turning in the wrong direction and this could damage the pump.

In this case, invert the electric power supply phase in the plug and then repeat the operation.

4.8 *Installing the pulling arm*

- 5 Raise the bench to about 1 mt height.
- 6 Disassemble the front side of the pulling tower: Hooking attachment, spring-holder plate, springs and spacers, bearings.

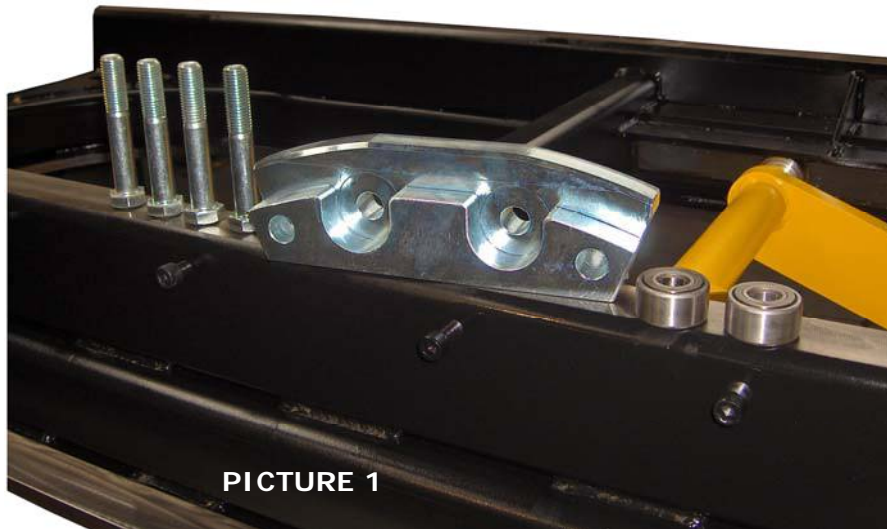

PICTURE 1

- 7 Insert pulling tower on the bench.

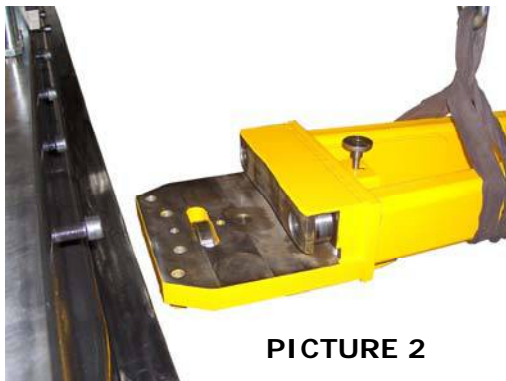

PICTURE 2

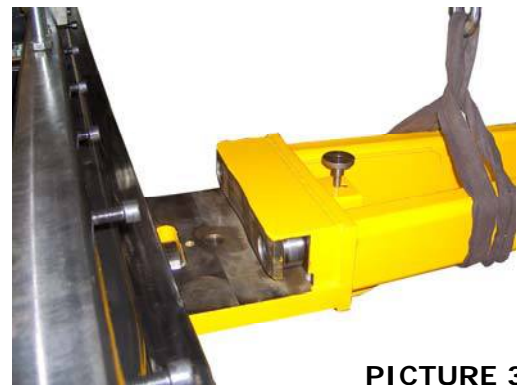

PICTURE 3



PICTURE 4

8 Insert the two bearings.

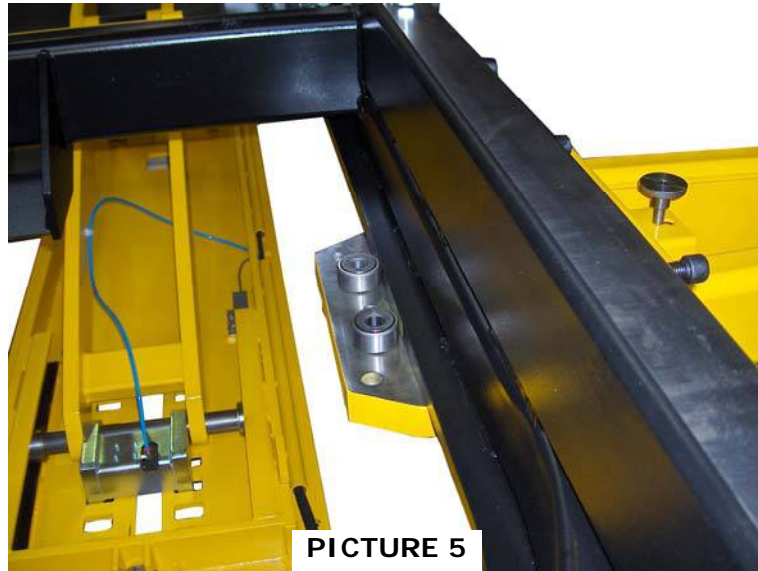

5 Position the hooking attachment, insert bolts from above toward the lower part then screw nuts and clench.



- 6 Blocking of the Pulling tower.
Blocking is by a knob. (Picture 8)

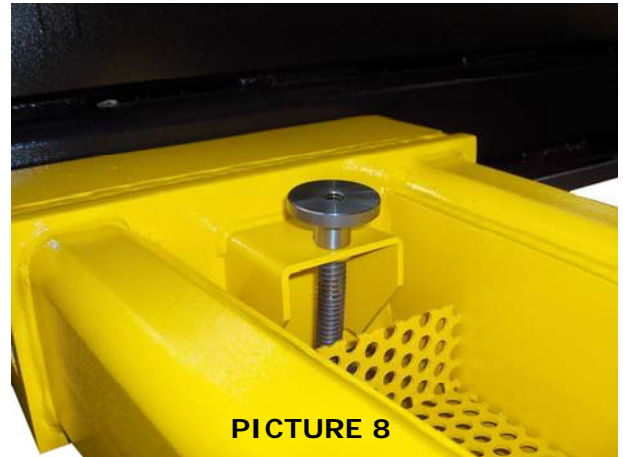

- 7 To unlock the pulling Tower pull up the knob and push toward the bench (Picture 9)

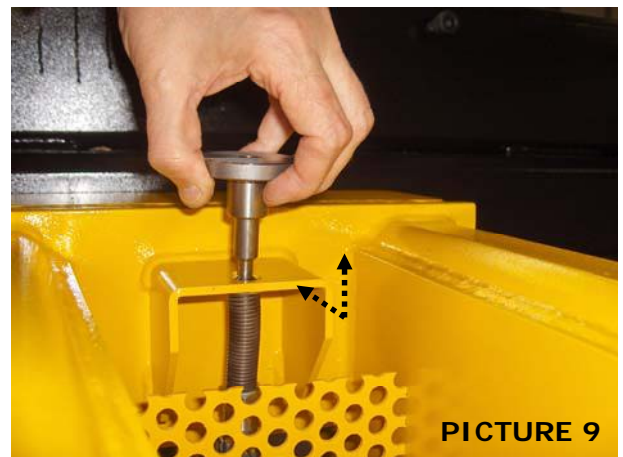

- 8 Position the rod in the smallest slot, now the arm can move freely (Picture 10)

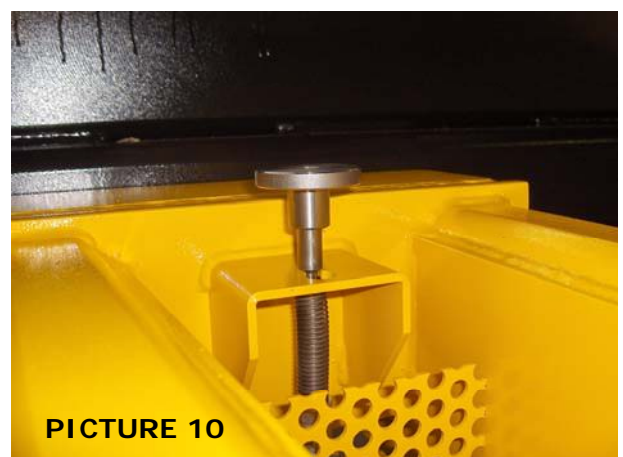

- 9 To lock the arm put the Knob in the initial position. (See Picture 8)

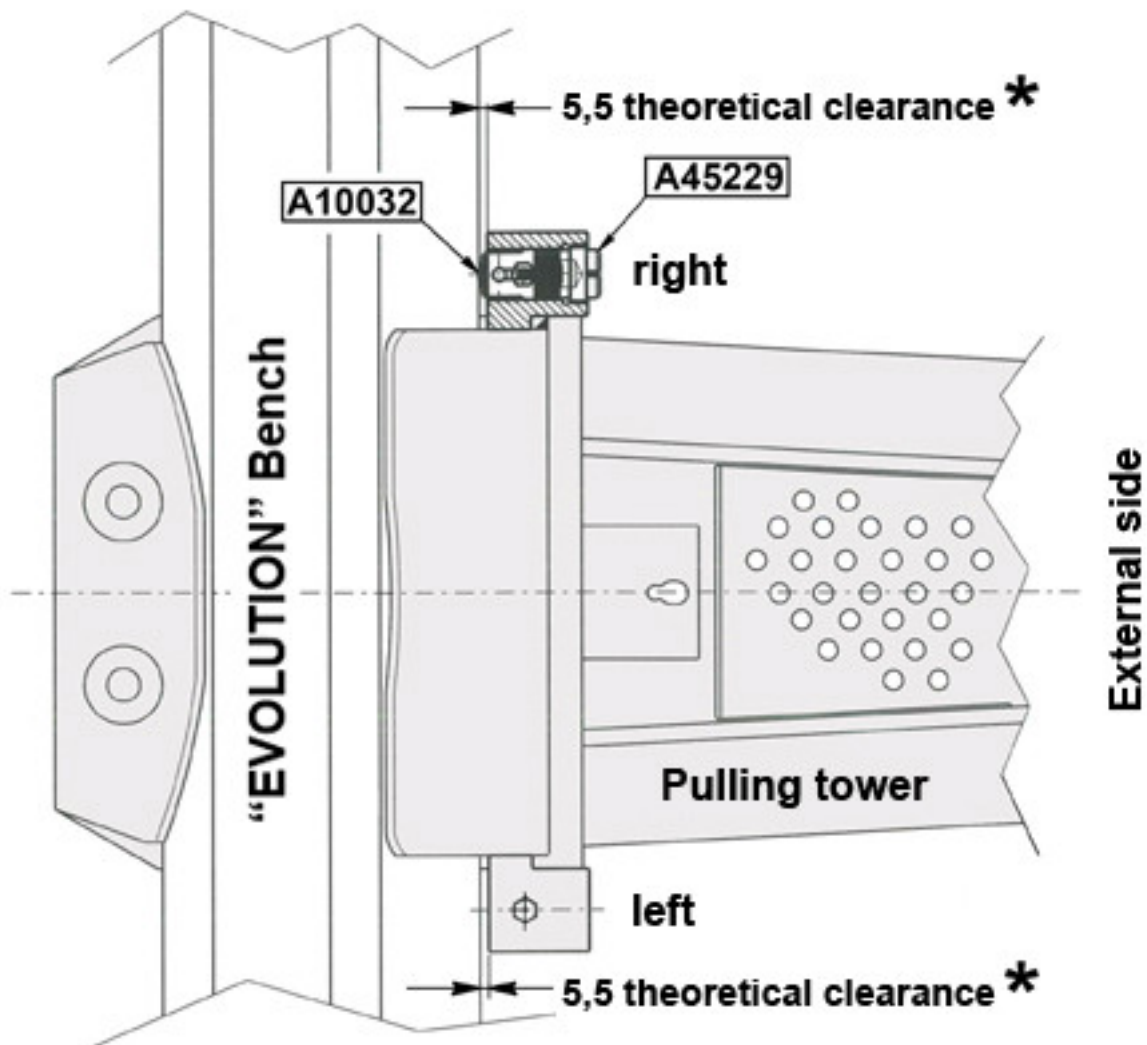

“Clearance” adjustment

- 1 - Position the Pulling tower on the straight part of the Bench.
- 2 - Turn screw A45229 to move the wheel A10032 closer to the lower profile of the Bench both on the right and left. Put it so it only touches without forcing it. Make sure that the clearance between the Pulling tower and Bench is the same on the right and left side.
- 3 - Move the pulling tower to check that it moves smoothly.
- 4 - Fine-tune if necessary.

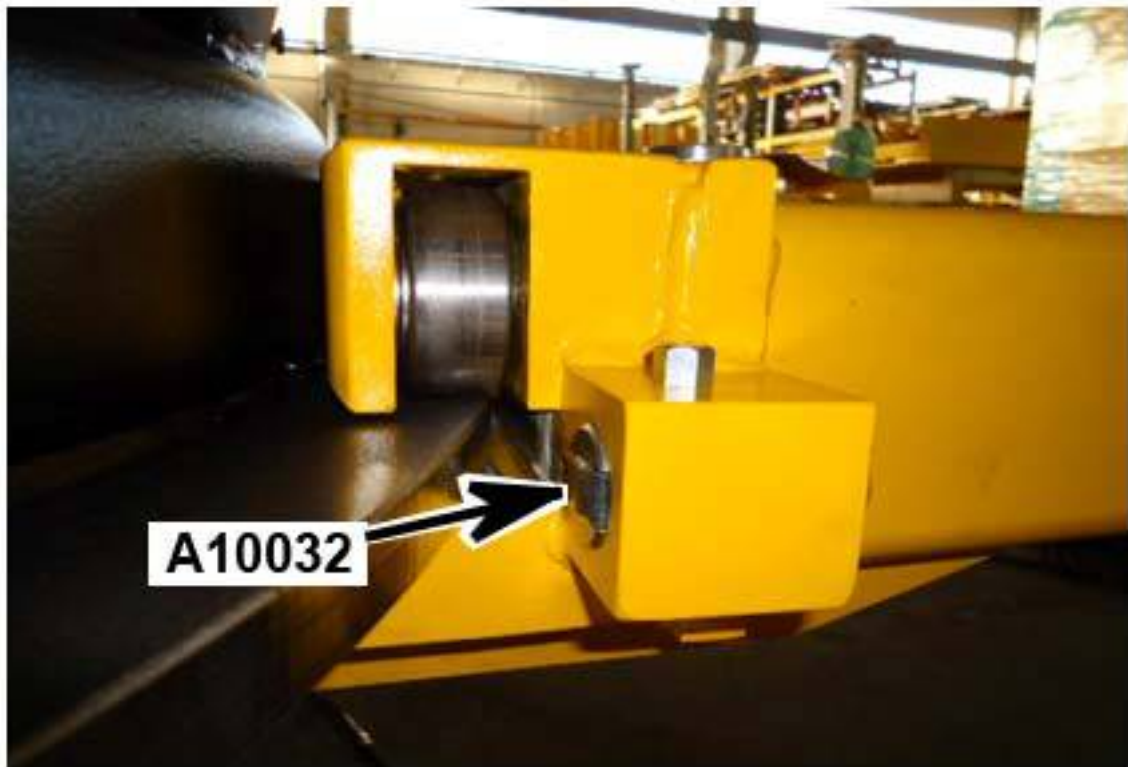
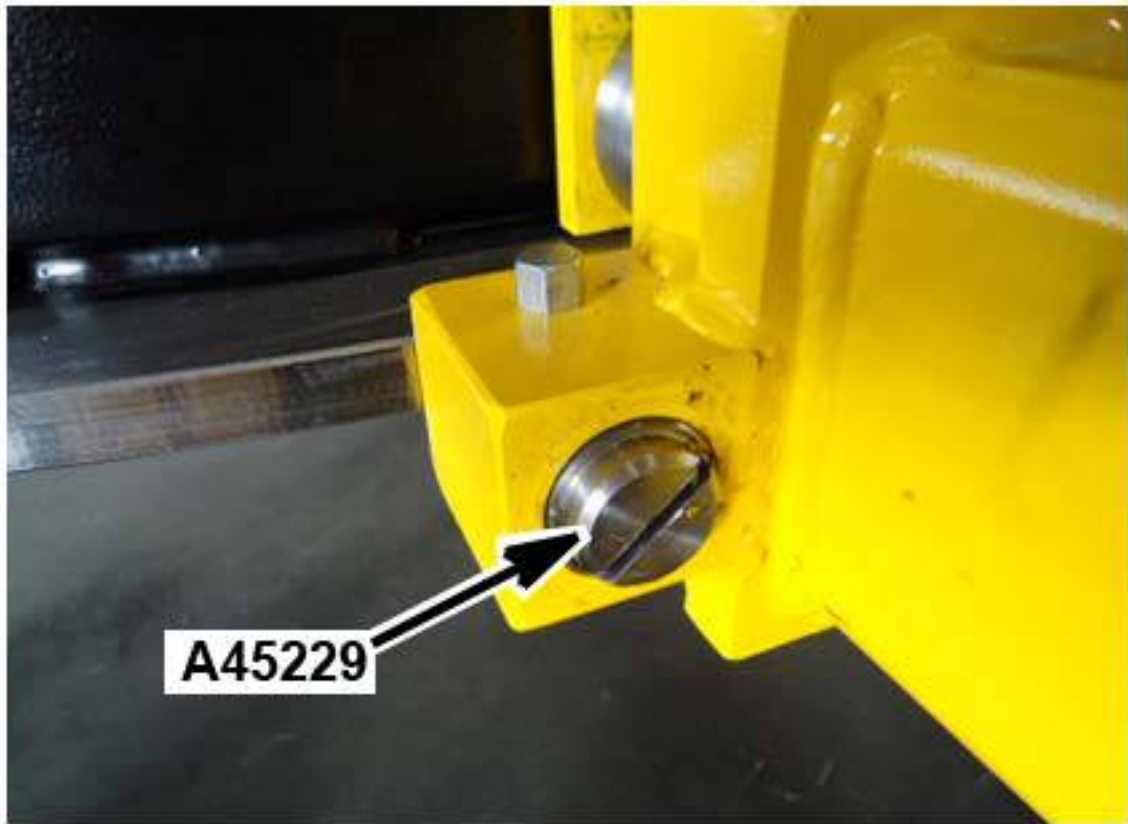

5 OPERATING INSTRUCTIONS

5.1 Introductory note

Given the way the LB is used, the operator is only required to perform simple operations. Throughout use — i.e. when lifting and lowering a vehicle — the user must always stay at a safe distance (at least 1.5 meters) from the LB and control the operations using the mobile button strip.

!! DANGER !!

During lifting and lowering operations, the above distance guarantees greater safety should objects or the load drop from the LB

!! WARNING !!

GLOBALJIG declines any responsibility for anything that may result from noncompliance with the instructions in this manual.

!! DANGER !!

Before performing any lifting or lowering operations, the operator must make certain that there is at least 50 cm of free space between all mobile parts of the LB or lifted vehicle and any other nearby structures, whether fixed or mobile.

!! DANGER !

The vehicles lifted must be empty and not have anyone onboard.

5.2 Controls

The controls are illustrated in the figure below



FIG. 5.1

1	Emergency button
2	Up button
3	Down and safety Release button
4	Selector

- The lowering button has a double action mechanism: the first opens the outflow solenoid valve, while the second disengages the safety catch device. 



1	16° MAIN SWITCH
2	INDICATOR LIGHT
3	EVOLUTION BOARD
4	FUSE 6.32X32 1A 500V
6	FUSE 5X20 2 A
7	BUTTON PANEL
8	3+G MOBILE PLUG
9	AIR SOLENOID V.
10	SHEATH KIT COMPLETE WITH CABLE
11	ELECTRICAL SYSTEM COMPARTMENT
12	MOTOR 1.85 KW 4-POLE
13	HYDRAULIC CONTROL UNIT
14	PRODUCT IDENTIFICATION
15	LIMIT SWITCH

5.3 Operating procedures

Below you will find the operating procedures that are to be performed when using the LB.

a) Turning on the unit

- Check that the pneumatic supply is present at the control unit inlet.
- Check that the pneumatic supply is properly connected to the control unit and the LB.
- Check for electrical power supply to the control unit.
- Set the cutoff switch to «I» and check that the green light goes on.

b) Turning off the unit

- Lower the mobile frame all the way down.
- Set the cutoff switch to «0».

c) Lifting



- After having carried out the procedure to turn on the unit, check that there is nothing to prevent the LB from being lifted.
- Check that the vehicle on the LB (if present) is securely locked in place with the clamps and correctly resting on the rubber pads.
- Press the button (6, fig. 5.1) and keep it pressed until the LB has reached the desired height. Then release the button.
- Press the button (5, fig. 5.1) to lower the LB until it stops. Then release the button.

!!! DANGER !!!

Before approaching the LB to perform the necessary operations on the vehicle, turn the selector (3, fig. 5.1) to «0».

d) Lowering

Before lowering the unit, make certain that there is nothing under and/or to the side of the LB that would prevent it from being lowered.

- Operations for lowering
- Press the raise button  briefly to disengage the mechanical safety catch device.
- **The lowering button has a double action mechanism: the first opens the outflow solenoid valve, while the second disengages the safety catch device.** 
- Next, press the lowering button and hold it down until the desired position has been reached.

! ATTENTION! !

- Make sure that the button panel's cable does not pass through the frame.

e) Loading the vehicle on the LB

- Fully lower the lift and position the vehicle on it using the lift ramps. The vehicles lifted must be empty and not have anyone onboard.

The LB has a tilting system that facilitates vehicle loading

!! WARNING !

Disengage the tilting system by lowering the "tip" immediately after use or before lowering the load.

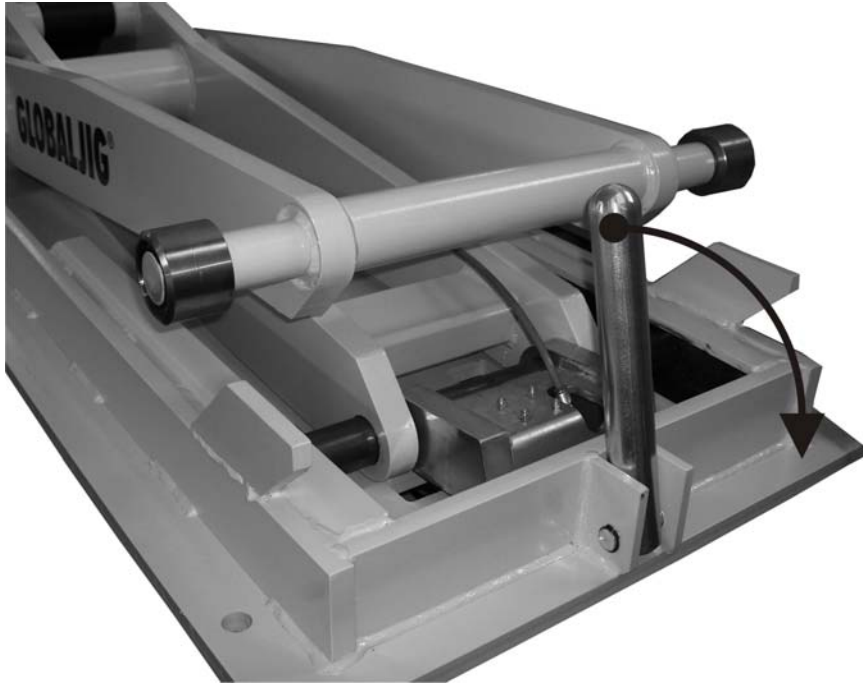

!!! DANGER !!!

Once the arm and chain have been set up, before starting the pulling operation, make certain that nobody is present in the immediate vicinity of the arm and, in particular, behind the arm.

5.4 Adjustments

The lift does not require any form of regulation during installation or operations.

6 SAFETY

6.1 Introduction

The LB has been designed and built in compliance with European Directives and the unified European regulations regarding human and environmental safety.

In fact, where possible, the hazards have been eliminated during the design stage; where not possible they have been limited and/or any residual risks have been highlighted.

If a situation arises which was not foreseen, and/or could not be foreseen, contact GLOBALJIG Technical Services before proceeding.

6.2 Safety devices

The LB does not have guards. User safety is guaranteed by the components and materials which ensure both functionality and user safety.

The control unit is protected by a structure.

Operations can only be performed on the unit by a specific operator and only after authorization by the manufacturer.

Achieving the highest degree of safety possible presumes that the recommendations found in this manual are followed to the letter, particularly those regarding the following aspects:

- the personnel performing the activities are qualified, as outlined in the pertinent paragraphs;
- the LB is used as rated, particularly in regard to maximum load and type of vehicle the EVOLUTION can lift;
- the LB is only used with vehicles that are empty and have no persons on board;
- no unauthorized persons are in the work area.

!! DANGER !!

Prior authorization from GLOBALJIG must be received before applying new devices, or modifying the existing devices. Noncompliance with this point relieves GLOBALJIG of any responsibility for the modifications made. Moreover, working under vehicles positioned on the LB is strictly forbidden.

6.3 Residual risks

The user and/or operator must read this paragraph carefully to ensure that they are aware of all risks involved in the use of the LB. This information, along with a thorough reading of the entire manual, will ensure that they are fully prepared and work in the proper manner. The activities involved in using the LB present the following residual risks:

- risk that, during body repairs, the links of the chain or parts of the chassis break and are thrown off at the back or in the immediate vicinity of the pulling arm;
- risk that the electrical power supply cable controlling the unit and the hoses (hydraulic and pneumatic) connecting the control unit and the lift are cut. If the hydraulic hoses get cut, the lift is kept in position by the “parachute valves” that close completely on the cylinder oil inlet and by the mechanical safety pawl that locks in place automatically.

7 MAINTENANCE

7.1 *Introductory note*

This chapter deals with scheduled and special maintenance.

Operators enabled to perform the maintenance activities indicated below require level 1 Qualification. All maintenance operations require the presence of one qualified operator. The electric and pneumatic power supplies must be cut off before performing any maintenance operations.

The term scheduled maintenance is used to indicate all those operations scheduled by the Manufacturer. On the other hand, unscheduled maintenance operations are considered special maintenance.

To prevent malfunctions or breakdowns that may stem from repairs — malfunctions that would be difficult to predict for anyone with thorough knowledge of the basic LB construction principles — any operations not outlined in the present manual and that would significantly affect LB function must be previously agreed upon with the GLOBALJIG Customer Services Department.

7.2 *Customer Services*

The LB is guaranteed for a period of 24 months. The warranty period starts from the moment the unit is shipped or delivered.

Technical service is guaranteed by the Manufacturer (or Area Distributor). Intervention time is limited to 48 hours (weekends and holidays not included) from the moment the call is received.

Contact the GLOBALJIG Customer Services Department by telephone or fax at the following numbers:

Telephone: +39 0585-8364 Fax: +39 0585-833880
--

7.3 Scheduled maintenance

The scheduled maintenance operations the manufacturer requires for the LB are outlined in the table below. The persons performing these operations must have level 1 Qualification.

FREQUENCY	DESCRIPTION OF OPERATION	PARAGRAPH
8 hours	Cleaning the LB	7.3.1
160 hours	Check safety pin efficiency	7.3.2

! NOTE ! *For maintenance of the hydraulic control unit, see the document supplied by the Manufacturer of that unit.*

7.3.1 Cleaning the lift

Using compressed air or a dry brush, carefully clean the entire LB and, in particular, the areas where the accessories are connected and area for the safety catches. With a rag, carefully clean the wheel "slide paths" (on the base and on the frame) and grease lightly with a common grease. Clean the pulling arm with a rag that is dry or slightly dampened with a detergent solution. Do not use water.

7.3.2 Checking safety lock status

- Test the piston that disengages the pawl to ensure that it is properly activated/deactivated with the "safe release" button (see fig. 5.1).
- Make certain that the pawl swings freely on its pin.
- Repeat this operation several times.

7.4 Special or unscheduled maintenance

Special or unscheduled maintenance involves the replacement of some LB components with reference to the list in Chapter 8. If it proves difficult to replace or obtain a component, contact the GLOBALJIG Customer Services Department for information.

!! WARNING !!

The use of anything but original, specific spare parts can alter the original configuration and lead to hazards that cannot be attributed to the LB. GLOBALJIG cannot be held responsible for any injury or damage to property or the system itself if non-original parts are used.

Special maintenance operations must be performed by qualified personnel.

8 SPARE PARTS

8.1 General information

When requesting spare parts, you must give GLOBALJIG the serial number of your LB, the item code and the quantity needed. This will ensure prompt identification of the part. GLOBALJIG pledges to supply said parts within 10 days of receipt of the request.

For specific requirements we suggest you send your order by fax as this will speed up delivery. GLOBALJIG's customer service and parts supply policy has defined minimum quantities. If the Customer requests fewer of a given component, GLOBALJIG can accept or reject the order at its own discretion.

8.2 Recommendations on the spare parts to be kept on hand

The parts of the LB that can be replaced are indicated in the table below.

PROGR. NUMBER	GLOBALJIG CODE	DESCRIPTION	RECOMMENDED QTY
1		Push-button panel, complete with cable	1
2		Fuses 10A - 500 V	5
3		Fuses 2A - 250 V	5
4		Fuses 16A	5

9 INSTRUCTIONS FOR DISMANTLING AND DISPOSING OF THE LIFT BENCH

9.1 Removing lift bench connections

Before performing any operations on the LB, thoroughly disconnect all sources of power to the unit. Disconnect the system connection hoses running between the control unit and the LB.

- Oil feed hose – limit switch cable
- Pneumatic feed hose – electrical cable

9.2 Arranging the lift bench for handling

Prepare the LB to be moved following the procedures indicated in paragraph 4.3 in reverse order.

To move the unit with a suitable form of lift, see the photograph below and carefully follow the type of equipment, operations and position.

If the unit is to be transported, package the LB as reported in paragraph 4.1.

9.3 Disposing of the lift bench

To dispose of the lift bench, all of its parts must be disposed of as wastes having mechanical components made of steel and aluminum alloys, and electrical components (control unit). These components must be disposed of through specialized companies in compliance with the laws in force in the User's country.

We recommend separating the materials to facilitate storage and recycling.

! NOTE !

As regards the oil present in the hydraulic circuit, it must be disposed of separately in compliance with the laws on toxic-harmful wastes in force in the User's country.

10 ATTACHMENTS

List of attachments

The EVOLUTION LB User's Manual contains the following attachments:

- Lift bench dimensions
- Lift bench work area
- Electrical wiring diagram
- Hydraulic system diagram
- Pneumatic system diagram
- Blow-up of pulling arm
- Blow-up of control unit
- Figures

10.1 Attachment 01 - Lift bench dimensions

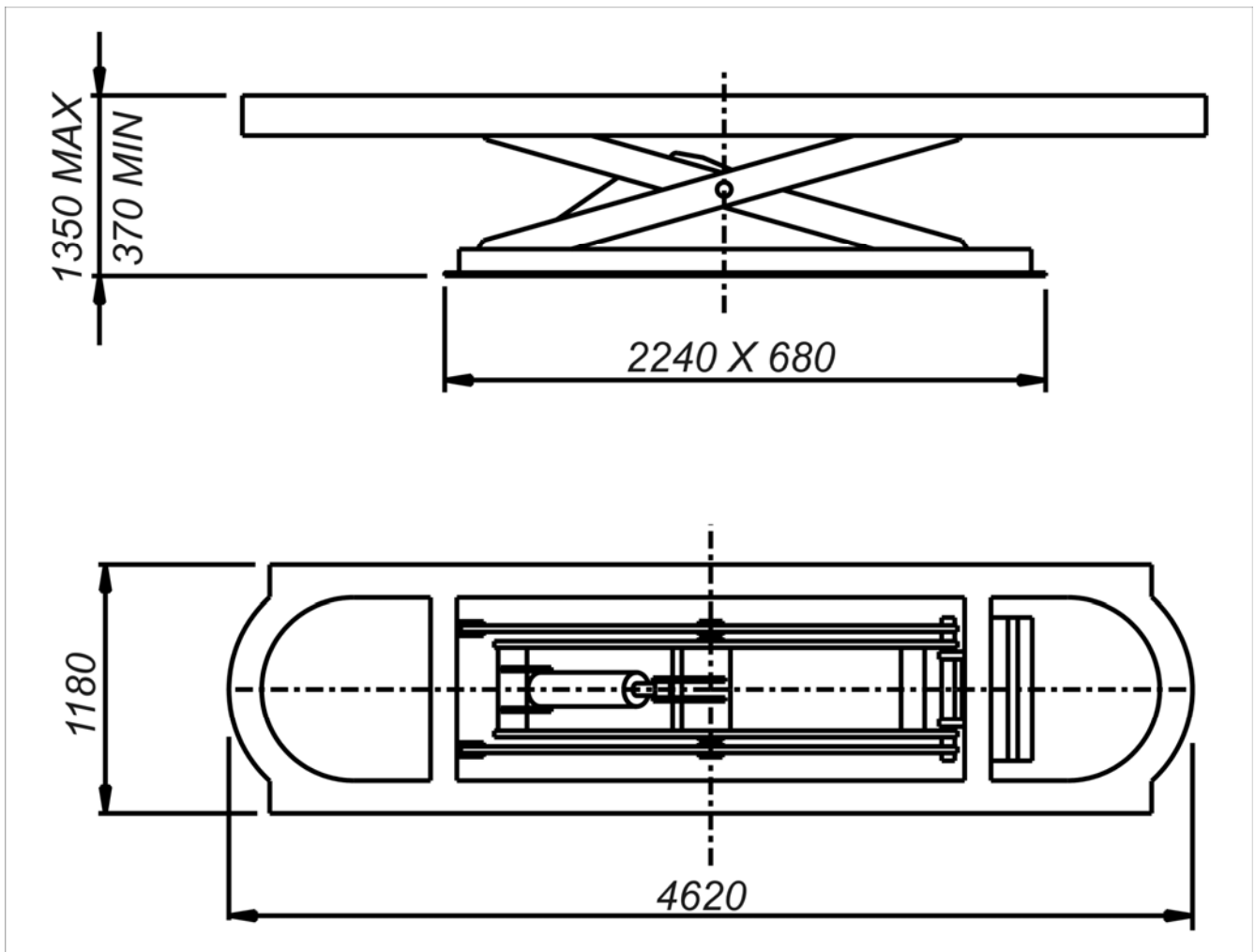

10.2 Attachment 02 - Lift bench work area

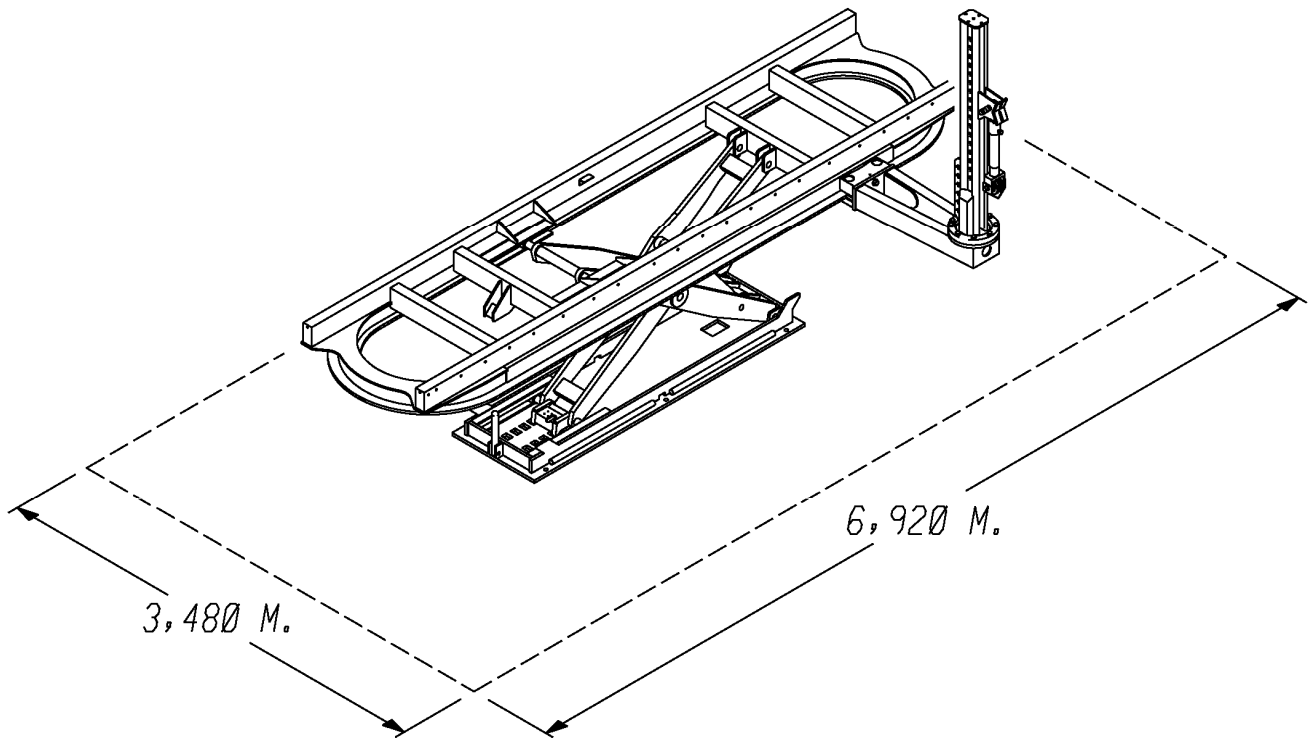

10.3 Attachment 03 - Electrical wiring diagram

400V 50Hz three-phase
(N.B. check the power supply version)

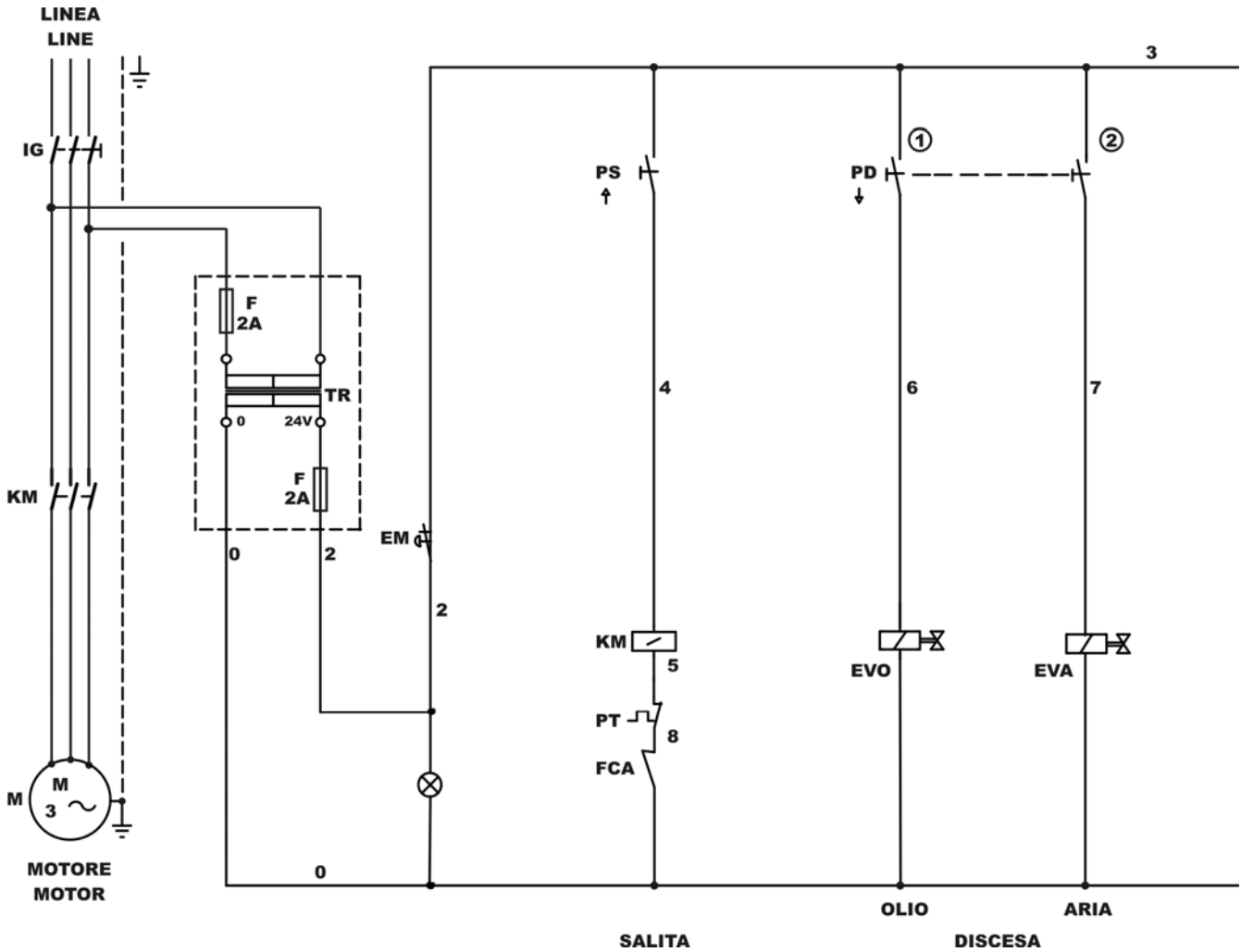

KM	CONTACTOR
M	MOTOR
PT	MOTOR HEAT SHIELD PAD
TR	TRANSFORMER
EM	EMERGENCY BUTTON
PS	UP BUTTON
PD	DOWN BUTTON
FCA	LIMIT SWITCH
EVO	AIR SOLENOID VALVE
EVA	DOWN CONTROL OIL SOLENOID VALVE
IG	MAIN CIRCUIT BREAKER

10.4 Attachment 04 – Electronic data

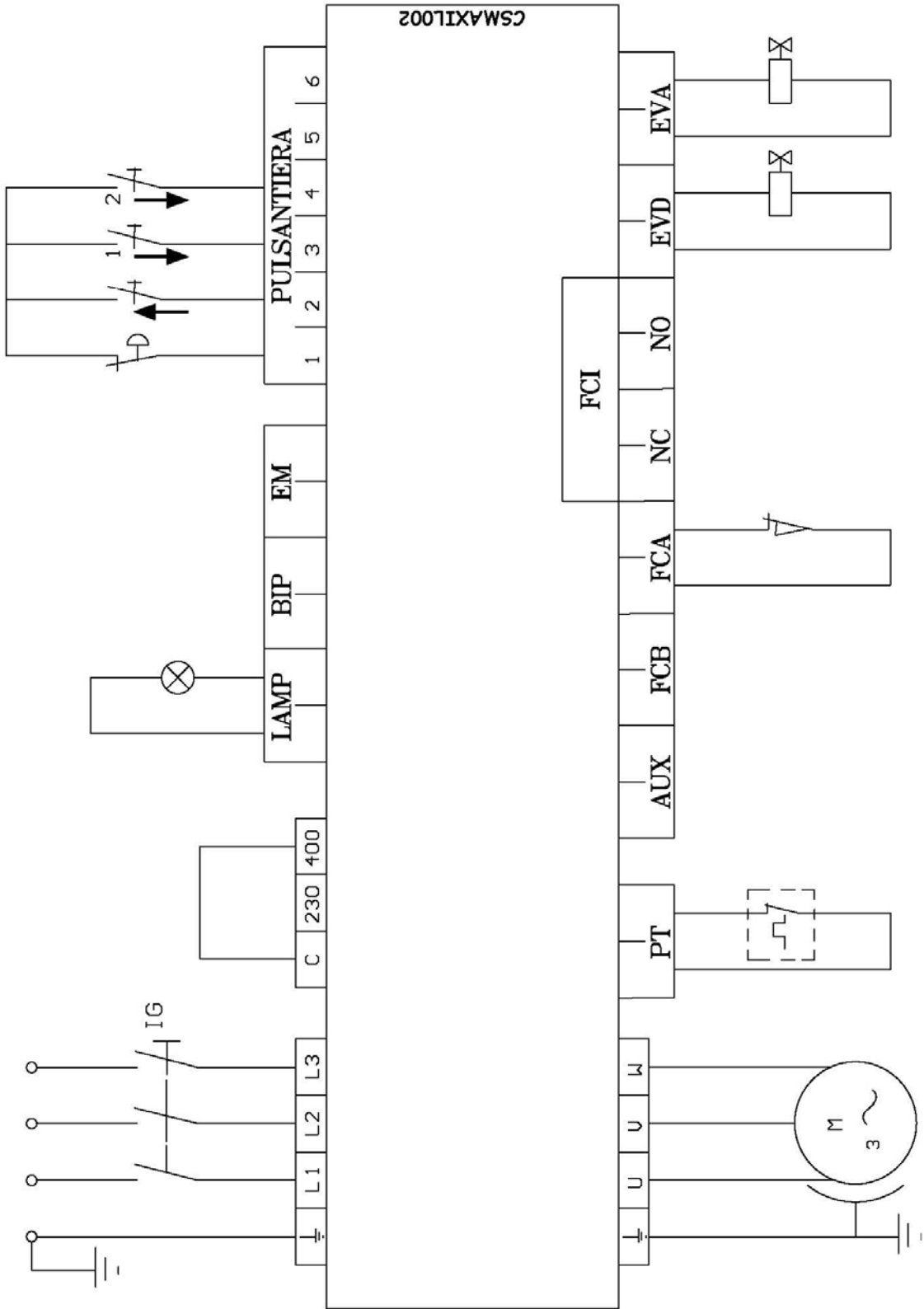

10.5 Attachment 05 - Hydraulic system diagram

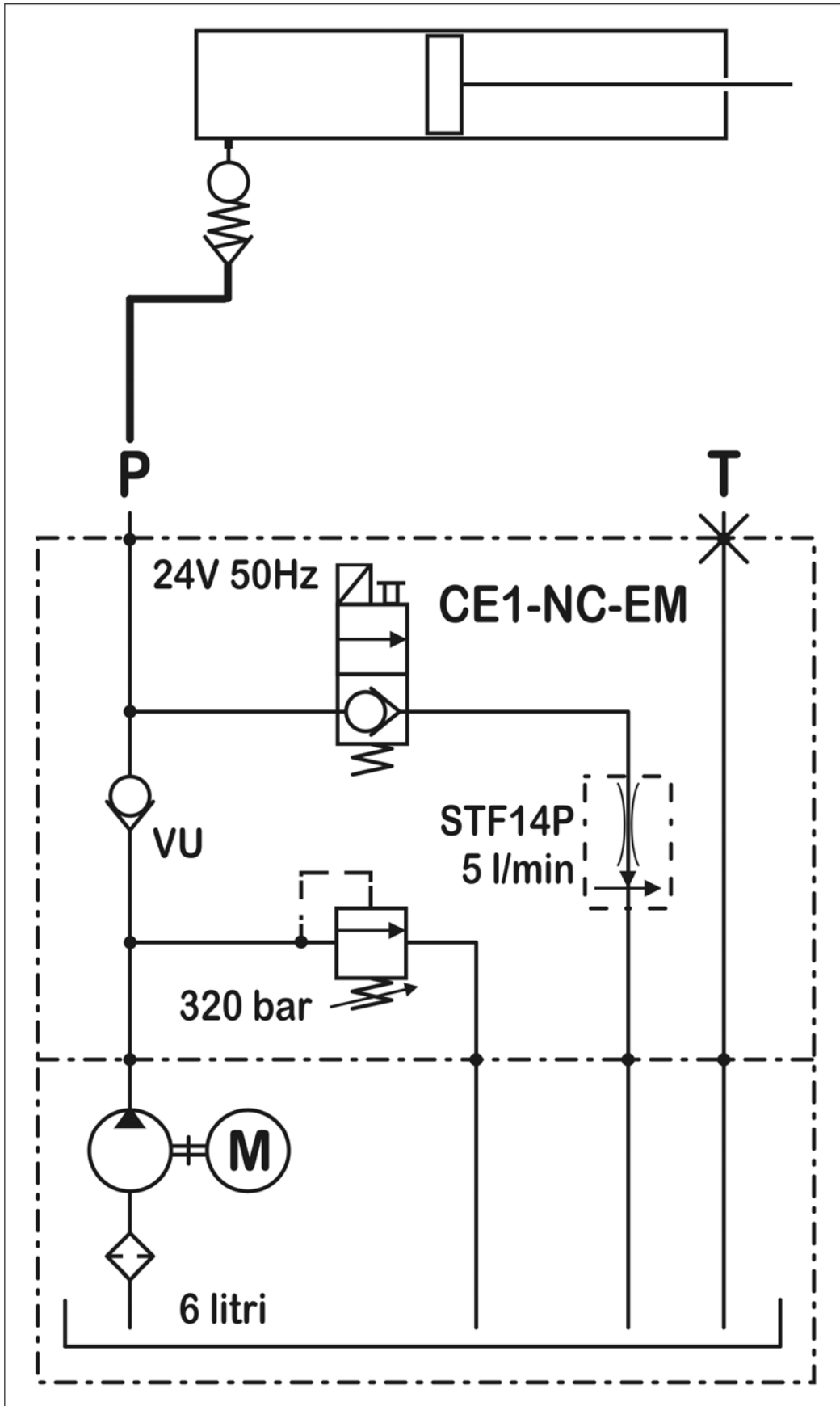

10.6 Attachment 06 - Pneumatic system diagram

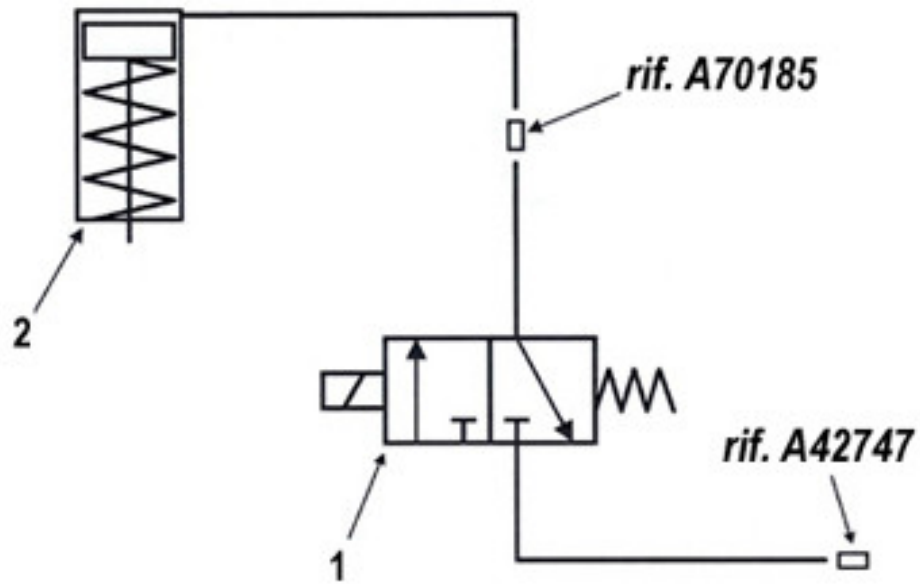

1 – 3-WAY PNEUMATIC SOLENOID
VALVE NORMALLY CLOSED

2 – SHORT STROKE PISTON
Bore dia. 3 – stroke 20
ARTEC FSR32-20

10.7 Attachment 07 - Blow-up of control unit

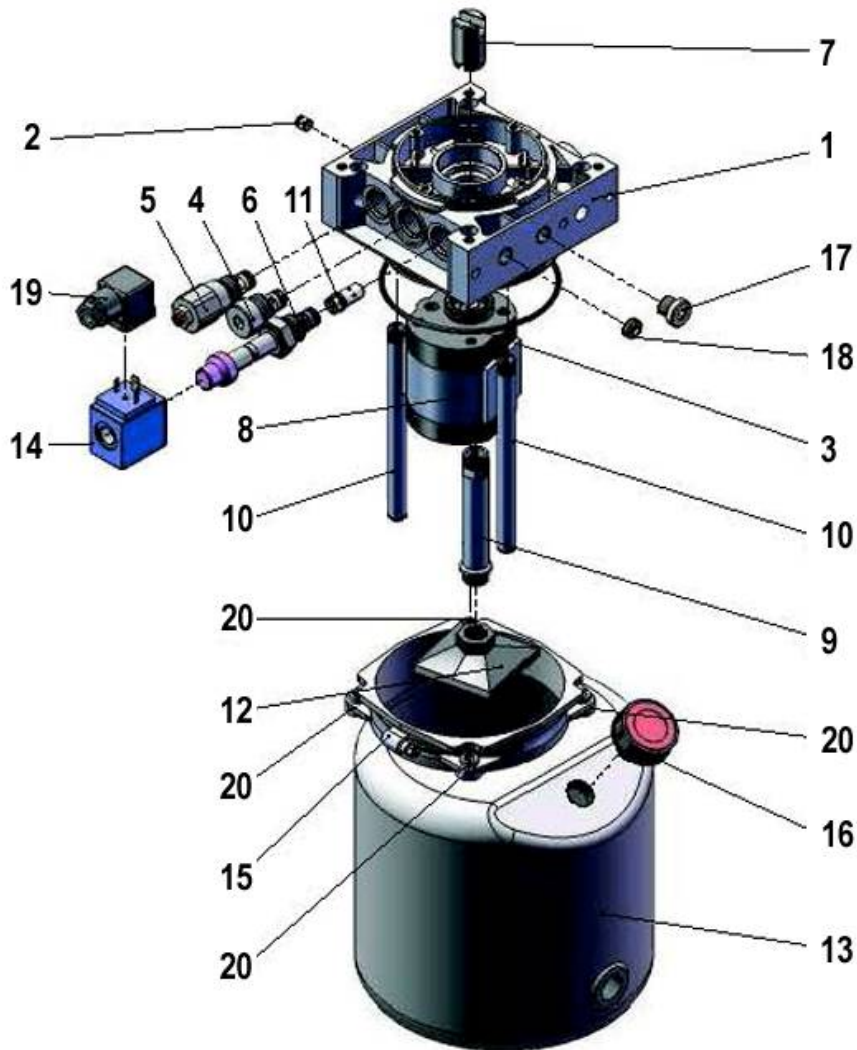

1	MANIFOLD	1
2	CAP	1
3	O-RING	1
4	VALVE	1
5	VALVE	1
6	VALVE	1
7	COUPLING	1
8	PUMP	1
9	SUCTION TUBE	1
10	DISCHARGE TUBE	2

11	CHOKE	1
12	FILTER	1
13	TANK	1
14	COIL	1
15	COLLAR	1
16	CAP	1
17	CAP	1
18	FILTER	1
19	CONNECTOR	1
20	SPECIAL NUT	4

10.8 Attachment 08 - Figures

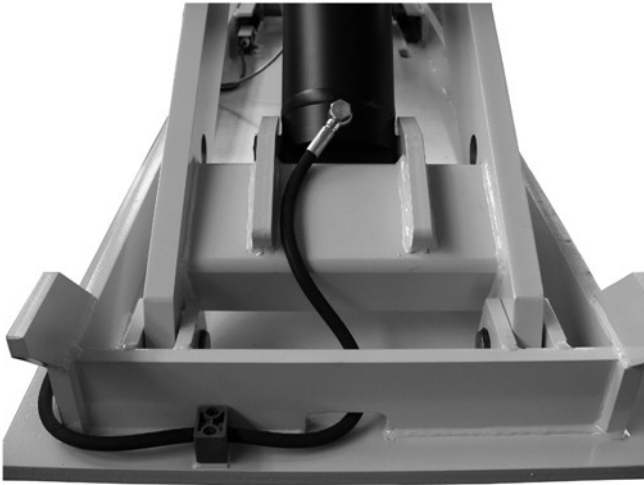

LIFT CYLINDER



UP LIMIT SWITCH

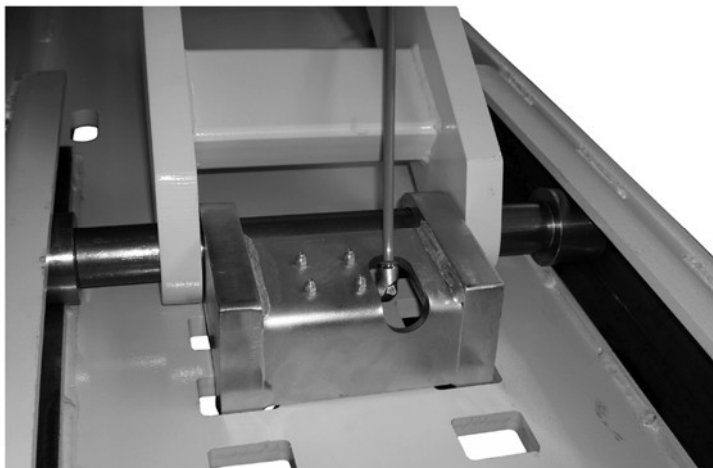
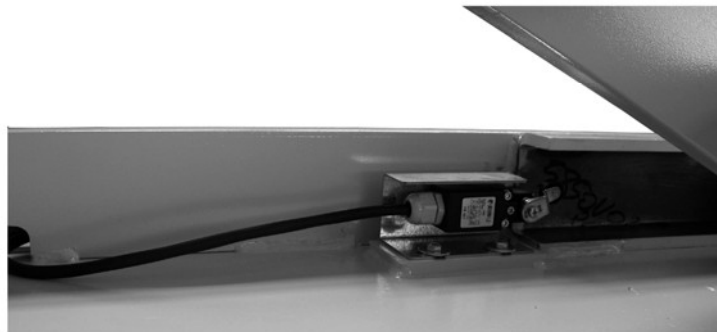

SAFETY PAWL

11. MACHINE LOG BOOK

Use the following form to make a note of the maintenance and any operations performed on the equipment. This will provide the user with the most appropriate information on the active cycle of the unit at all times.

Serial number		Date of initial operation		Page 1/2
.....			
DATE	Repair or programmed maintenance	Spare parts	Signature and/or stamp of the operator	

Serial number		Date of initial operation		Page 2/2
.....			
DATE	Repair or programmed maintenance	Spare parts	Signature and/or stamp of the operator	

GLOBALJIG *International S.r.l.*

**Società unipersonale sotto la direzione e controllo della Bellini Srl.
Iscritta al Reg. Imprese di Massa Carrara al N° 01064230459
Capitale sociale € 100.000,00 i.v.
Via Aurelia Ovest, Km. 383 - 54100 Massa (MS) - ITALY
Tel.: +39 0585 8364 - Fax: +39 0585 833880 - www.globaljig.it**

**Nessuna parte di questo documento può essere riprodotta né tradotta
in altra lingua senza la preventiva autorizzazione scritta della società
GLOBALJIG INTERNATIONAL S.r.l.
Tutti i diritti sono riservati**

**No part of this document may be reproduced or translated to other
languages without written permission from
GLOBALJIG INTERNATIONAL S.r.l.
All rights reserved**

GLOBALJIG *International* **S.r.l.**

Società unipersonale sotto la direzione e controllo della Bellini Srl.

Iscritta al Reg. Imprese di Massa Carrara al N° 01064230459

Capitale sociale € 100.000,00 i.v.

Via Aurelia Ovest, Km. 383 - 54100 Massa (MS) - ITALY

Tel.: +39 0585 8364 - Fax: +39 0585 833880 - www.globaljig.it