



5,5 / 7,5 TRUCK (FD)

MOBILE SINGLE COLUMN HYDRAULIC LIFT – FIXED DISPLAY

Basic information

Advantages



Trucks, buses, agro machines

5500
7500

Loading capacity [kg]

1800

Maximal lifting high [mm]

14-22,5"
585-1160

Dimensions of taken-on tires - trucks [mm]

up 32"
1905

Dimensions of taken-on tires - agro machines [mm]

1,5

Motor [kW]

4 - 12

Columns



- LOADING CAPACITY 5500/7500 kg
- HYDRAULIC DRIVE HIGHLY EFFICIENT AND ECONOMICAL
- ELECTRONIC REGULATION AND SYNCHRONIZATION OF OPERATION OF THE LIFT
- INTEGRATED DISPLAY WITH CONTROL PANEL
- POSSIBILITY OF DISTANT CONTROL BY MEANS OF SIGNAL FROM THE RANGE OF 863-868 MHZ (ACCORDING TO ETSI)
- FUNCTION OF PRECISE ARRIVAL TO THE REQUIRED HEIGHT
- ACOUSTIC SIGNALIZATION, PRINT-OUT OF REPORTS
- LIFTING OF BROAD RANGE OF VEHICLES FROM DELIVERY VANS TO OFF-HIGHWAY TRUCKS
- CZECH MADE
- LIFTS ARE DESIGNED AND MANUFACTURED IN ACCORDANCE WITH ČSN EN 1493:2010



INTEGRATED DISPLAY WITH CONTROL PANEL



CONTROL PANEL



POWER PACK COVER WITH ELECTRO BOX



TECHNICAL DATA

AMI 5,5 TRUCK / 7,5 TRUCK

Technical drawing for mobile single column hydraulic lift

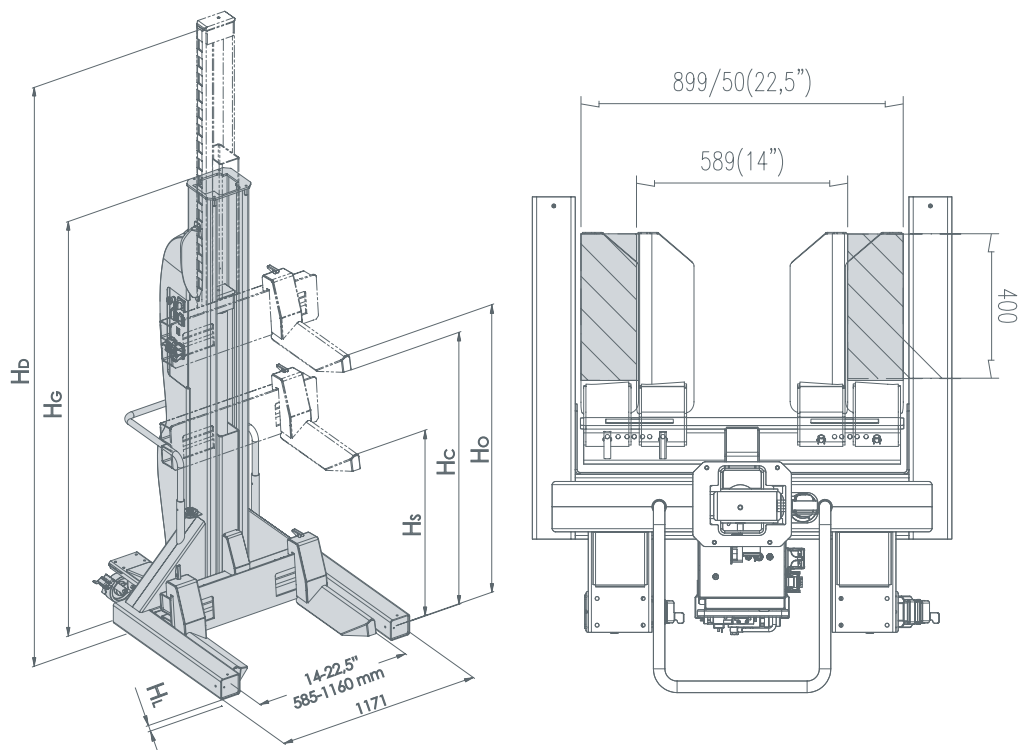

Packing dimensions

TYPE	LENGTH	WIDTH	HEIGHT	GROSS WEIGHT
AMI 5,5 / 7,5 TRUCK	1,4 m	1,25 m	2,8 m	520 kg

▪ right to make technical changes reserved

Technical data

	4 - 6 columns	8 - 12 columns	
Maximal lifting capacity of a separate post	5500 / 7500 kg		
Time of lifting	95 s		
Time of lowering	89 s		
Power supply network	TN-S 3/N/PE 400/230V AC, 50 Hz		
Motor of each post	1,5 kW		
Maximal electric input	15 kW	19 kW	
Maximal upstream protection	25A/C EN 60898-1 A	32A/C EN 60898-1 A	
Upstream protection for maximal loading capacity	20 A/C	25 A/C	25 A/C 32 A/C
Maximal lifting capacity of the lifting mechanism at full number of the posts	30 t	36 t	36 t 45 t
Outside dimensions of the post	1171 x 1378 x 2659 mm		
Dead weight of the post (net)	510 kg		
Maximal lifting high H_c	1800 mm		
Maximal height of the slides H_o	1918 mm		
Maximal height of taking-on by chassis H_s	1100 mm		
Headroom of the carriage unit of the non-loaded pillar H_L	23 mm		
Total height of the post H_G	2659 mm		
Dimensions of taken-om tires - trucks	14-22,5" / 585-1160 mm		
Dimensions of taken-om tires - agro machines	up 32" / 1905 mm		

▪ right to make technical changes reserved



TANDEM INTERCONNECTION

AMI 5,5 TRUCK / 7,5 TRUCK

Example of interconnection - fixed display 4 + 4 columns

Example of interconnection - mobile tablet 6 + 6 columns

SET A

SET B

SET A

SET B

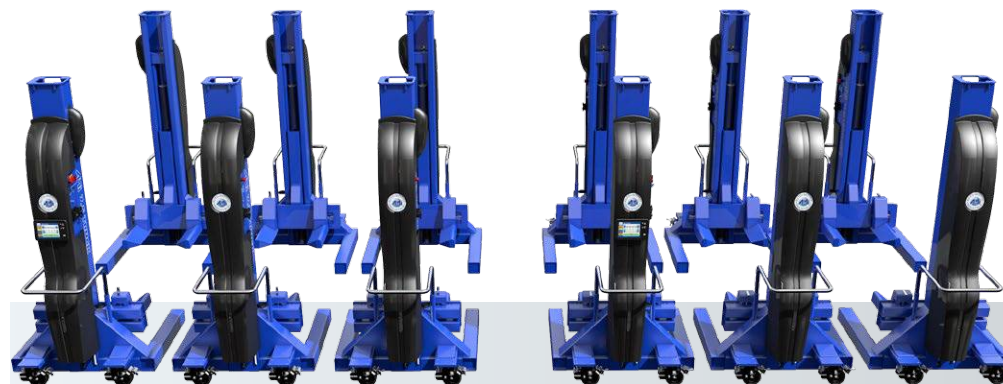
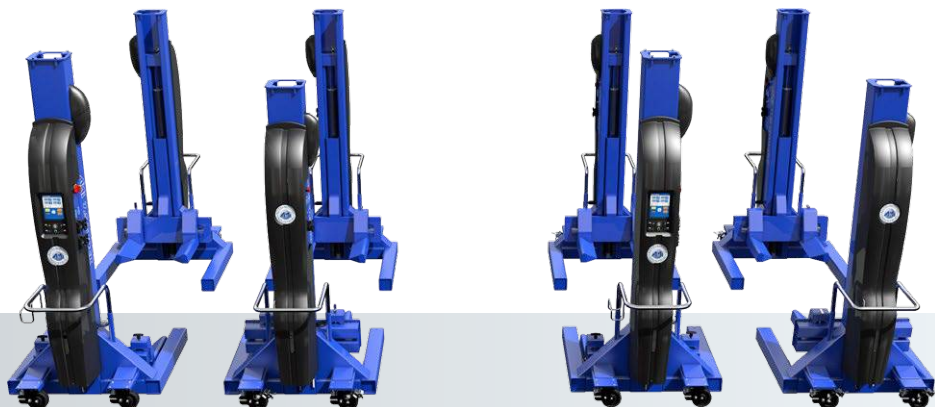



ACCESSORIES

MOBILE SINGLE COLUMN HYDRAULIC LIFT

Mobile tablet



- 391514-80-11

Remote control



- Independent remote control (suitable for fine regulation)
391514-80-09

Electro box on MASTER column



- 391514-80-03

Electro box on SLAVE column



- 391514-80-04

Agro - accessories

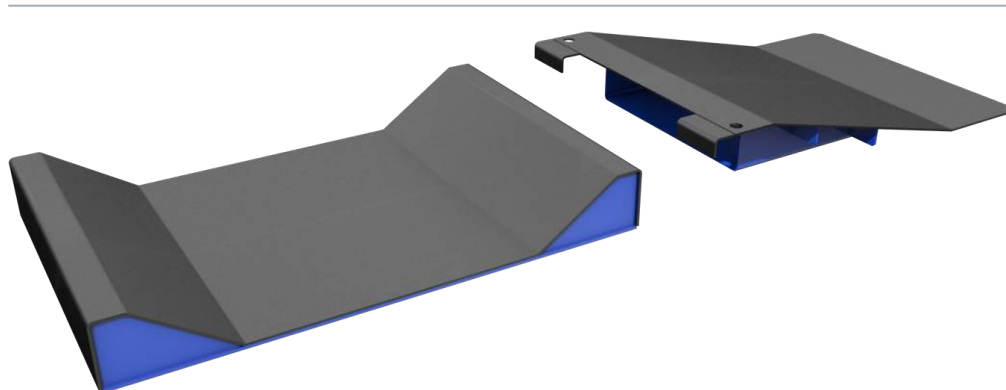

- 391220-00-00