

Product code: FG 722/5T

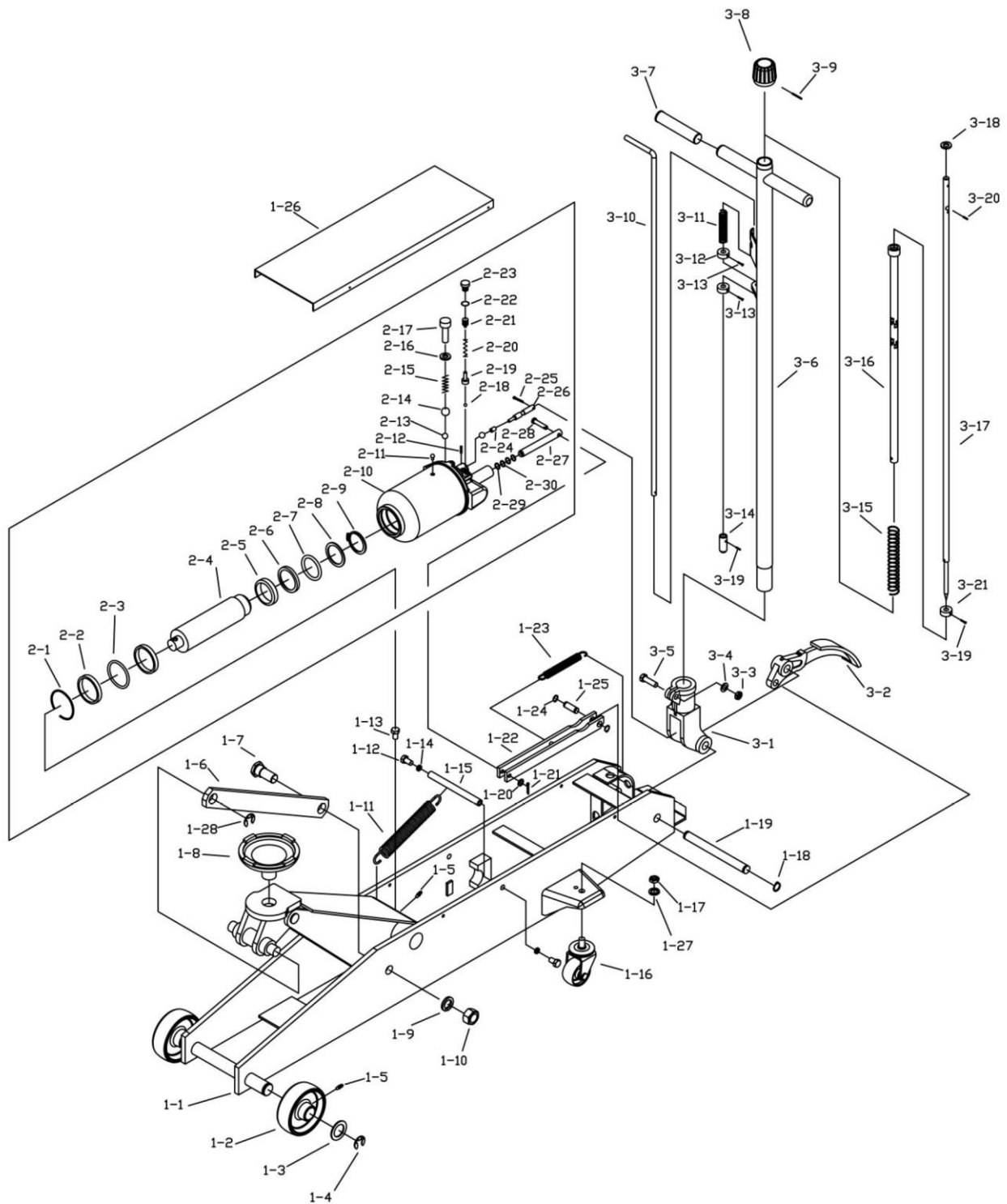

REF.	CODE	DESCRIPTION	CONTENT	Q.TY/EACH TOOL
2-1	FG 722/5T-1	Pump assembly	Snap ring	1
2-2			Washer	
2-3			O-ring	
2-4			Piston rod	
2-5			Piston ring	
2-6			Sealing washer	
2-7			O-ring	
2-8			O-ring retainer	
2-9			Snap ring	
2-10			Oil cylinder assembly	
2-11			Oil filler plug	
2-12			Pin	
2-13			Steel ball Ø6	
2-14			Steel ball Ø9	
2-15			Spring	
2-16			Copper washer	
2-17			Bolt M12x20	
2-18			Steel ball	
2-19			Valve seat	
2-20			Spring	
2-21			Screw	
2-22			O-ring	
2-23			Safety valve screw	
2-24			Seals	
2-25			Pin	
2-26			Release valve rod	
2-27			Cylinder pump plunger	
2-28			Pin	
2-29			O-ring	
2-30			Nylon gasket	
1-26	FG 722/5T-2	Cover board		1
1-8	FG 722/5T-3	Saddle		1
1-11	FG 722/5T-4	Spring		1
1-23	FG 722/5T-5	Spring		1
1-2	FG 722/5T-6	Front wheel	Front wheel	2
1-3			Washer	
1-4			Snap ring	
1-5			Grease fitting	

REF.	CODE	DESCRIPTION	CONTENT	Q.TY/EACH TOOL
1-16	FG 722/5T-7	Rear wheel	Rear wheel	2
1-17			Nut	
1-27			Lock washer	
3-7	FG 722/5T-8	Complete handle	Handle sleeve	1
3-8			knob	
3-9			Pin	
3-10			Control rod	
3-11			Spring	
3-12			Washer	
3-13			Screw	
3-14			Rod joint	
3-15			Spring	
3-16			Universal joint assembly	
3-17			Convey rod	
3-18			Washer	
3-19			Pin	
3-20			Pin	
3-21	Washer			
3-2	FG 722/5T-9	Foot pedal	Pedal	1
3-3			Nut M10	
3-4			Washer	
3-5			Bolt M10x35	